

INSTALLATION INSTRUCTIONS

EV^RHEAT™ SERIES 20



Read carefully for proper installation and operation.

EV^RHEAT engine heating systems feature advanced temperature sensors and fluid detection capability in a easy-to-install package, providing consistent temperature management, reliable engine starts and reduced maintenance.

⚠ DANGER



Personal injury: This product generates heat during operation. Operation of a heating system with closed isolation valves could result in high pressure and serious injury. It is the responsibility of the installer and operator to ensure that no unsafe condition can result from the generation of pressure. In EU countries, PED (97/23/EC) compliant pressure relief may be required (125 psi maximum).

Hazardous voltage: Before wiring, servicing or cleaning the heating system, turn off the power and follow your organization's lockout and tagout procedure. Failure to do so could allow others to turn on the power unexpectedly, resulting in harmful or fatal electrical shock.

⚠ CAUTION

Electrical hazard: Power source must be properly grounded and in accordance with national and local electrical codes. A user-supplied circuit breaker (rated at the appropriate amperage) is required for use in the main power feed line. Do not connect heater prior to installation.

NOTICE

Read instructions carefully: The Hotstart warranty does not cover any damage that a heating system may sustain from improper installation, improper operation, improper specification or corrosion. Before installing your heater, be sure you have the right heating system for your application. Carefully read all instructions before installing and energizing your heater. The safety of any system incorporating this heater is the responsibility of the assembler. The safe and proper use of this heater is dependent upon the installer following sound engineering practices. If the equipment is used in a manner not specified by the manufacturer, the protection provided by the equipment may be impaired. All applicable electrical safety standards defined by local jurisdictions must be followed.

Note: This equipment has been tested and found to comply with the limits for a Class A digital device, pursuant to part 15 of the FCC Rules. These limits are designed to provide reasonable protection against harmful interference in a residential installation. This equipment generates, uses and can radiate radio frequency energy and, if not installed and used in accordance with the instructions, may cause harmful interference to radio communications. However, there is no guarantee that interference will not occur in a particular installation. If this equipment does cause harmful interference to radio or television reception, which can be determined by turning the equipment off and on, the user is encouraged to try to correct the interference by one or more of the following measures:

- Reorient or relocate the receiving antenna.
- Increase the separation between the equipment and receiver.
- Connect the equipment into an outlet on a circuit different from that to which the receiver is connected.
- Consult the dealer or an experienced radio/TV technician for help.

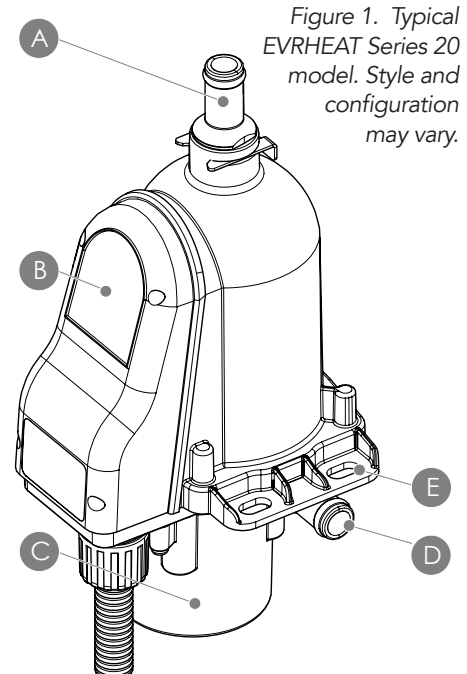
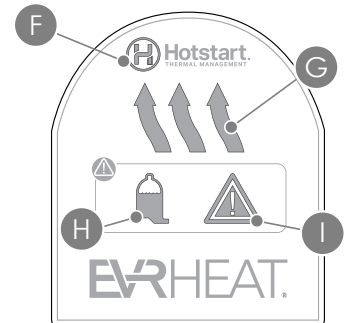

Figure 1. Typical EV^RHEAT Series 20 model. Style and configuration may vary.

- | | |
|---|---|
| A. Discharge port
0.625" (16 mm)
hose barb | D. Suction port
0.625" (16 mm)
hose barb |
| B. LED Interface | E. Mounting slot × 4
0.33" (8.42 mm) |
| C. Pump/motor | |



- | | |
|----------------------------|------------------------|
| F. Power On | H. Fluid Fault |
| G. Heater Operation | I. System Fault |

Corporate & Manufacturing Headquarters
 Spokane, WA, USA
 509.536.8660
 sales@hotstart.com

Hazardous Location & Marine Office
 Katy, TX, USA
 281.600.3700
 hazloc@hotstart.com
 marine@hotstart.com

Railroad Office
 Merrillville, IN, USA
 219.648.2448
 railroad@hotstart.com

Europe Office
 Koln, Germany
 +49.2203.98137.30
 europe@hotstart.com

United Kingdom Office
 Birmingham, UK
 +44.0121.809.5468
 UK@hotstart.com

Asia Pacific Office
 Tokyo, Japan
 +81.3.6902.0551
 apac@hotstart.com

Hotstart Manufacturing, Inc. is the owner of all trademarks and copyrightable material contained herein; all rights are reserved; no form of reproduction is authorized without prior written consent from Hotstart Manufacturing, Inc.

OVERVIEW

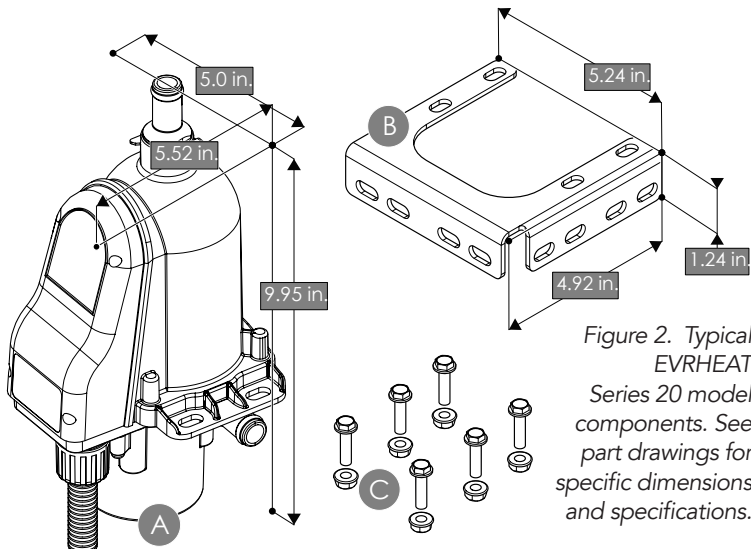

Figure 2. Typical EVRHEAT Series 20 model components. See part drawings for specific dimensions and specifications.

PARTS LIST

SUPPLIED PARTS

- A. EVRHEAT Series 20 engine heater
- B. Mounting bracket (3/8 slots)
- C. Mounting bracket fasteners × 6 (5/16-18 X 0.875)
- D. 0.625" (16 mm) hose barb × 2 (shown installed on heater)
- E. Hose barb installation clips × 2 (shown installed on heater)

RECOMMENDED USER-SUPPLIED PARTS

- Engine port fittings × 2 (min. size 3/8 inch NPT (10 mm))
- Full-flow isolation valves × 2
- Hose (min. dia. 5/8" (16 mm) rated for 250 °F/121 °C/ 100 psi (690 kPa))
- Hose clamps

INSTALLING THE HEATER

PREPARE COOLANT SYSTEM

1. Drain and flush cooling system to remove any debris present in the engine's cooling system.

SELECT PORTS

2. Select return port on the engine. The return port will allow heated coolant to return to the engine. The return port must be located:
 - Near the rear (flywheel) of the engine
 - Away from the engine thermostat
 - Away from the supply port
 - On the same side of the engine as the intended heater mounting location
3. Select supply port on the engine. The supply port will allow coolant to flow from the engine to the heater. The supply port must be located:
 - Near the front of the engine (near radiator)
 - At the lowest point of the engine's water jacket
 - Away from the return port

NOTE: For V-type engines, it is acceptable to select a supply port on the opposite side of the engine as long as the supply hose is routed properly. See **PLUMB HEATER**.

SELECT HOSE, FITTINGS & VALVES

4. Select fittings for the engine ports. EVRHEAT Series 20 minimum engine port size fitting:
 - 3/8 inch NPT (10 mm)
5. Select hoses. EVRHEAT Series 20 minimum hose inner diameter:
 - 5/8 inch (16 mm)

NOTE: Select hoses rated for 250 °F (121 °C) and 100 psi (690 kPa) minimum.

6. Select optional, user-supplied isolation valves.

NOTE: Hotstart recommends installing valves to isolate the heating system in case of service. To minimize flow restriction, select full-flow (full-port) ball isolation valves.

MOUNT HEATER

NOTICE

Vibration damage: Do not mount heater directly to engine. Engine vibration will damage heater. If the heater is installed with rigid pipe, connect flexible hose to inlet and outlet to isolate from vibration.

Heater orientation: EVRHEAT Series 20 units must be installed with discharge port pointing directly upward. Do not mount at an angle. An incorrectly oriented heater may cause heater failure.

7. Select a heater mounting location. The heater should be mounted:
 - Low to ensure the return hose continuously rises to the return port
 - On the same side of the engine as the return port
 - In a position to ensure the discharge port points directly upward.
8. Mount heater to vibration-isolated surface using supplied mounting bracket and fasteners. Mounting bracket may be installed in the following orientation options:

Figure 3. Bracket options.

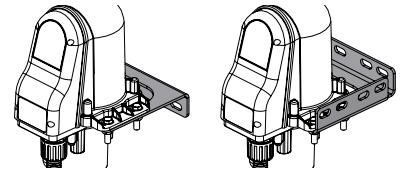

PLUMB HEATER

NOTICE

High points: Do not allow high points along heater plumbing. High points will restrict coolant flow and damage heater. To avoid high points, it may be necessary to change hose routing or lower heater mounting location.

Dips and bends: Do not allow dips or bends along heater plumbing. Dips or bends will allow air pockets to form, restricting coolant flow and damaging heater.

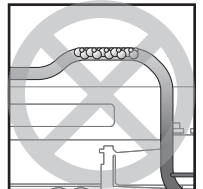

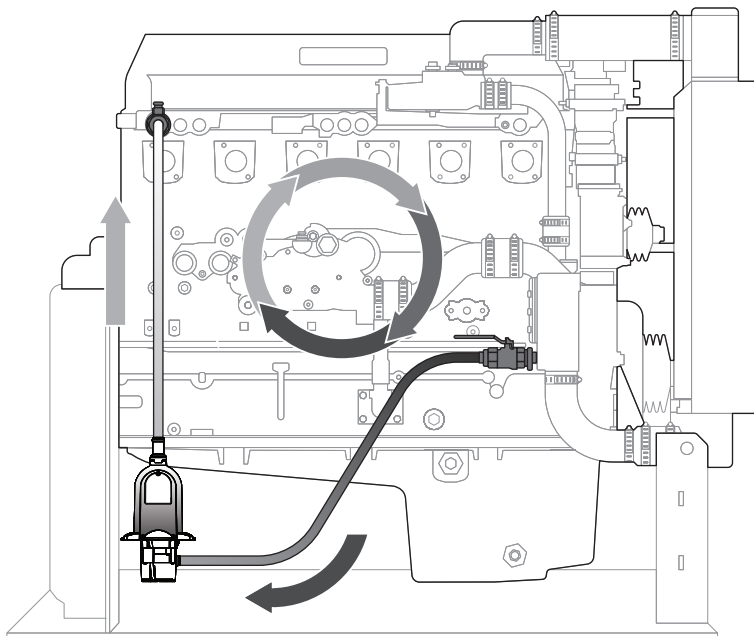

Figure 4. Example EVRHEAT Series 20 heater installation. Hose routing allows for continuous rise and descent with no dips, bends or high points. Heater is mounted in correct orientation and isolated from engine vibration.

90° Fittings: Elbows (90° fittings) along heater plumbing may restrict flow and damage heater. To minimize flow restriction, Hotstart recommends sweeping bends or 45° fittings in place of 90° fittings.

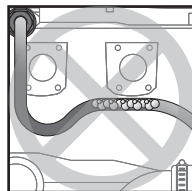

Figure 5. Rotate suction port.

9. Install isolation valves to port fittings. Ensure isolation valves are open.
10. If necessary, rotate heater suction port to attach supply hose (see Figure 5).
11. Route and install return hose. The return hose should continuously rise from the heater to the return port.
12. Route and install supply hose. The supply hose should continuously descend from the supply port to the heater.
13. Mix coolant according to your engine manufacturer's recommendations. Refill cooling system with coolant.

NOTE: Hotstart recommends using a 50% deionized or distilled water to 50% low-silicate antifreeze mixture.
14. Start engine. Allow engine to run until engine thermostat opens, purging air from cooling system.
15. Allow engine to cool. Check coolant level and top off as needed. **NOTICE!** Engine must be run to eliminate air from heating system before energizing heater.

CONNECT HEATER

16. Secure power cord at intervals to avoid contact with all hot or moving parts.
17. Connect heater to a properly grounded power source following national and local electrical codes.

NOTE: Once energized, heater will momentarily display all interface and fault lights before normal heating operation.

OPERATION

Once connected to power, the EVRHEAT Series 20 engine heating system will begin maintaining engine temperature. Reference the following interface lights for operation status:

Power		On/Green	Power to heater unit
		Off	Unplugged/no power
Heater Operation		Breathing Orange	Approaching temperature setpoint.
		Solid Orange	Holding/Above temperature setpoint
		Off	Pump/element in standby

TROUBLESHOOTING

To ensure reliable engine heating and protect equipment, the EVRHEAT series 20 heating system will monitor and display faults related to fluid flow and heating:

Power/ All Lights		Off/No lights illuminated	No device power. ➤ Verify unit is supplied with appropriate power.
Fluid Fault		Solid	Air pocket detected. ➤ Verify fluid presence. ➤ Verify isolation valve(s) open.
		Flashing	EVR20 remains in startup mode. ➤ Verify fluid presence. ➤ Verify fluid flow through heater.
System Fault		Flashing	EVR20 system fault present. ➤ Contact Hotstart.

If necessary, perform the following troubleshooting steps:

1. Verify fluid flow:
 - Ensure isolation valve(s) are open.
 - Remove 90° bends and excessive hose lengths. If necessary, reroute hoses or change port locations.
 - Flush cooling system of contaminants and refill.
 - Remove hose high points such as routing over the top of the engine. Remove hose dips and bends. If necessary, reroute hoses or change port locations.
 - Remove air from engine cooling system by running engine to operating temperature.
 - Check engine coolant level and top off as necessary.
2. Energize heater. After all indicator and fault lights initially display, note any remaining lights displayed (excluding **Power On**):
 - If **System Fault** , the heater will attempt to restart the pump every 60 seconds until either the issue resolves itself or the end-user intervenes.
 - If the system is obstructed by engine coolant contaminants (e.g., rust or debris), flushing the EVR20 with clean fluid or water while it is unpowered may

clear this error. A fluid pre-filter may be needed to prevent obstructions.

from heating system before energizing heater.

MAINTENANCE & PARTS

CAUTION

Electrical hazard: Before wiring, servicing or cleaning the heating system, turn off the power and follow your organization's lockout and tagout procedure. Failure to do so could allow others to turn on the power unexpectedly, resulting in harmful or fatal electrical shock.

Personal injury: If equipped with isolation valves, ensure valves are open before energizing heater. Obstructed flow may result in an unexpected release of heated coolant, potentially causing serious injury.

PREVENTATIVE MAINTENANCE

Annually:

- Drain, clean and flush the cooling system.
- Check and replace cracked or weakened hoses.
- Check electrical wiring for wear and excessive heat.

HOSE BARB REPLACEMENT

To accommodate various engine installations, the EVRHEAT model may use either 5/8 inch hose barbs or optional 3/4 inch hose barbs. Contact Hotstart for additional hose barb options.

1. Disconnect heater from power source. Allow heating system to cool.
2. Close isolation valves or drain coolant from heating system. Detach return and supply hoses from heater.
3. Remove hose barb clip. Remove hose barb.
4. Insert replacement hose barb. Ensure hose barb is fully seated.
5. Insert hose barb clip to lock hose barb in place.
6. Reattach return and supply hoses. Open isolation valves.

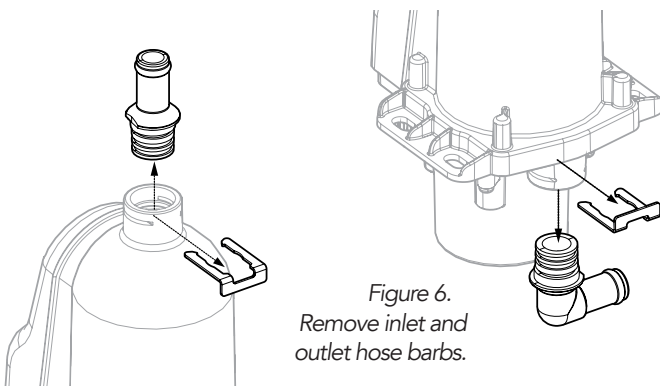

7. Start engine. Allow engine to run until engine thermostat opens, purging air from cooling system.
8. Allow engine to cool. Check coolant level and top off as needed. **NOTICE!** Engine must be run to eliminate air

Supplier's Declaration of Conformity 47 CFR § 2.1077 Compliance Information for Hotstart EVRHeat Series 20

This device complies with Part 15 of the FCC Rules. Operation is subject to the following two conditions: (1) This device may not cause harmful interference, and (2) this device must accept any interference received, including interference that may cause undesired operation.

Note: This equipment has been tested and found to comply with the limits for a Class A digital device, pursuant to part 15 of the FCC Rules. These limits are designed to provide reasonable protection against harmful interference when the equipment is operated in a commercial environment. This equipment generates, uses, and can radiate radio frequency energy and, if not installed and used in accordance with the instruction manual, may cause harmful interference to radio communications. Operation of this equipment in a residential area is likely to cause harmful interference in which case the user will be required to correct the interference at his own expense.

Hotstart 5723 E. Alki Ave., Spokane, WA 99212 USA
+1 509-536-8660 | sales@hotstart.com