

INSTALLATION & OPERATION MANUAL

COOLANT CIRCULATING HEATING SYSTEM
FOR HAZARDOUS LOCATIONS

MODEL

CSE

(this page intentionally left blank)

IDENTIFYING YOUR SYSTEM

IOM216318-000

The HOTSTART heating system is designed to heat fluids for use in heavy equipment applications. Each heating system component has an identification plate which includes the part number and serial number.

When ordering replacement parts, be sure to reference your heating system component's **MODEL NUMBER** and **SERIAL NUMBER** found on the identification plate and following label:



HOTSTART. 	SPOKANE, WA U.S.A.	REF. SERIAL NUMBER WHEN ORDERING REPLACEMENT PARTS
MODEL _____		
VOLTS _____ HERTZ _____		
AMPS. _____ PHASE _____		
CONTROL CIRCUIT VOLTS _____		
CONTROL CIRCUIT AMPS. _____ MAX		
SERIAL NUMBER _____		U.S. PATENTS 4,245,593, 4,249,491 CAN. PATENTS 1,067,473, 1,062,541
CAUTION OPEN CIRCUITS BEFORE WORKING ON THIS EQUIPMENT OR REMOVING COVERS. KEEP COVERS TIGHTLY CLOSED WHILE CIRCUITS ARE ALIVE.		

NOTE: Typical heating system identification plate. Your identification plate may vary.

WARRANTY INFORMATION

Warranty information can be found at www.hotstart.com or by contacting our customer service department at **(509)536-8660**. Have your **MODEL NUMBER** and **SERIAL NUMBER** ready when contacting the warranty department.

**Corporate & Manufacturing
Headquarters**
5723 E. Alki Ave
Spokane, WA 99212 USA
509.536.8660
sales@hotstart.com

Oil & Gas Office
21732 Provincial Blvd.
Suite 170
Katy, TX 77450 USA
281.600.3700
oil.gas@hotstart.com

Europe Office
HOTSTART GmbH
Am Turm 86
53721 Siegburg, Germany
+49.2241.12734.0
europe@hotstart.com

Asia Pacific Office
HOTSTART Asia Pacific Ltd.
2-27-15-4F Honkomagome
Bunkyo-ku, Tokyo
113-0021, Japan
+81.3.6902.0551
apac@hotstart.com

IMPORTANT SAFETY INFORMATION

DANGER

Hazardous voltage: Before wiring, servicing or cleaning the heating system, turn off the power and follow your organization's lockout and tagout procedure. Failure to do so could allow others to turn on the power unexpectedly, resulting in harmful or fatal electrical shock.

WARNING



Electrical hazard: All electrical work must be done by qualified personnel in accordance with national, state and local codes.

CAUTION

Read instructions carefully: The safety of any system incorporating this heater is the responsibility of the assembler. The safe and proper use of this heater is dependent upon the installer following sound engineering practices. If the equipment is used in a manner not specified by the manufacturer, the protection provided by the equipment may be impaired. All applicable electrical safety standards defined by local jurisdictions must be followed. (Reference EU directive 2006/95/EC in EU countries.)

- **Read carefully:** Installers and operators of this equipment must be thoroughly familiar with the instructions in this manual before commencing work.
- **Hot surfaces:** Avoid contact with the system while it is in service. Some surfaces may remain hot even if the system is not energized.
- **Proper lifting:** Use proper lifting equipment and rigging to move this equipment. Create a plan before attempting to move. Proper lifting locations are identified with labels on each system; use these locations when lifting and mounting the system.
- **Rotating equipment:** The heating system can start automatically and without warning. Avoid contact unless a lockout at the service panel has been installed.
- **Grounding:** The heater must be connected to a suitable ground (protective earthing conductor).
- **Overcurrent limiting:** The power supply must be protected by a suitable overcurrent limiting device.
- **Power disconnection:** A means to disconnect the heater from the power supply is required. HOTSTART recommends that a power switch or circuit breaker be located near the heating system for safety and ease of use.

NOTICE

EU Countries only: Equipment rated for the conditions listed in EN 601010-1 1.4.1 Ingress protection rating IP54. (Special conditions for specific applications may apply.)

TABLE OF CONTENTS

1	OVERVIEW 1		
1.1	HEATING SYSTEM COMPONENTS 1	4.2.2	Electrical Connections 10
1.2	OPERATION OVERVIEW 2	4.2.3	System Mounting 10
2	INSTALLATION 3	4.2.4	Magnetic Contactors 10
2.1	COOLANT PLUMBING INSTALLATION 4	4.2.5	Pump Seal 11
2.1.1	Coolant Supply 4	4.2.6	Pressure Relief Valve 11
2.1.2	Coolant Return 4	4.2.7	Pressure/ Temperature Gauge 11
2.1.3	Coolant Pressure Relief 4	4.2.8	Volatile Corrosion Inhibitor 11
2.2	MOUNTING 4	4.2.9	Temperature Control Relay 12
2.2.1	Tank and Pump 4	4.2.10	Control Resistance Temperature Device (RTD) 13
2.3	COOLANT PLUMBING ILLUSTRATION 5	4.2.11	Heating Tank/Elements 14
2.4	ELECTRICAL CONNECTIONS 6	4.2.12	Reassembly of Heating Element and Tank 14
2.4.1	Main Power Supply 6	4.3	RECOMMENDED MAINTENANCE 16
2.4.2	Motor Rotation Check 6	4.4	STORAGE REQUIREMENTS 16
2.4.3	Customer Interface Connections 6	4.5	TROUBLESHOOTING 17
3	COMPONENTS AND OPERATION 8		
3.1	SYSTEM COMPONENTS 8		
3.1.1	Motor Protection Switch 8		
3.1.2	Control TCR (Temperature Control Relay) 8		
3.1.3	High-Limit TCR (Temperature Control Relay) 8		
3.2	INTERFACE COMPONENTS 9		
3.2.1	Local/Off/Remote Switch 9		
3.2.2	Prime Button 9		
3.2.3	Reset Button 9		
3.2.4	Pressure/Temperature Gauge 9		
3.2.5	Pressure Relief Valve 9		
3.3	HEATING SYSTEM START-UP 9		
3.3.1	First Run Procedure 9		
4	MAINTENANCE, REPAIR AND TROUBLESHOOTING 10		
4.1	SYSTEM FAULTS 10		
4.1.1	Coolant Faults 10		
4.2	SYSTEM MAINTENANCE 10		
4.2.1	Plumbing Connections 10		

(this page intentionally left blank)

1 OVERVIEW

⚠ WARNING

System location classification: Before installing the CSE heating system, ensure all system components are suitable for the intended installation location by referring to the location classification labeling attached to the individual system components.

1.1 HEATING SYSTEM COMPONENTS

NOTE: Component illustrations are for reference only and are not to scale. See part drawings for dimensions and specifications.

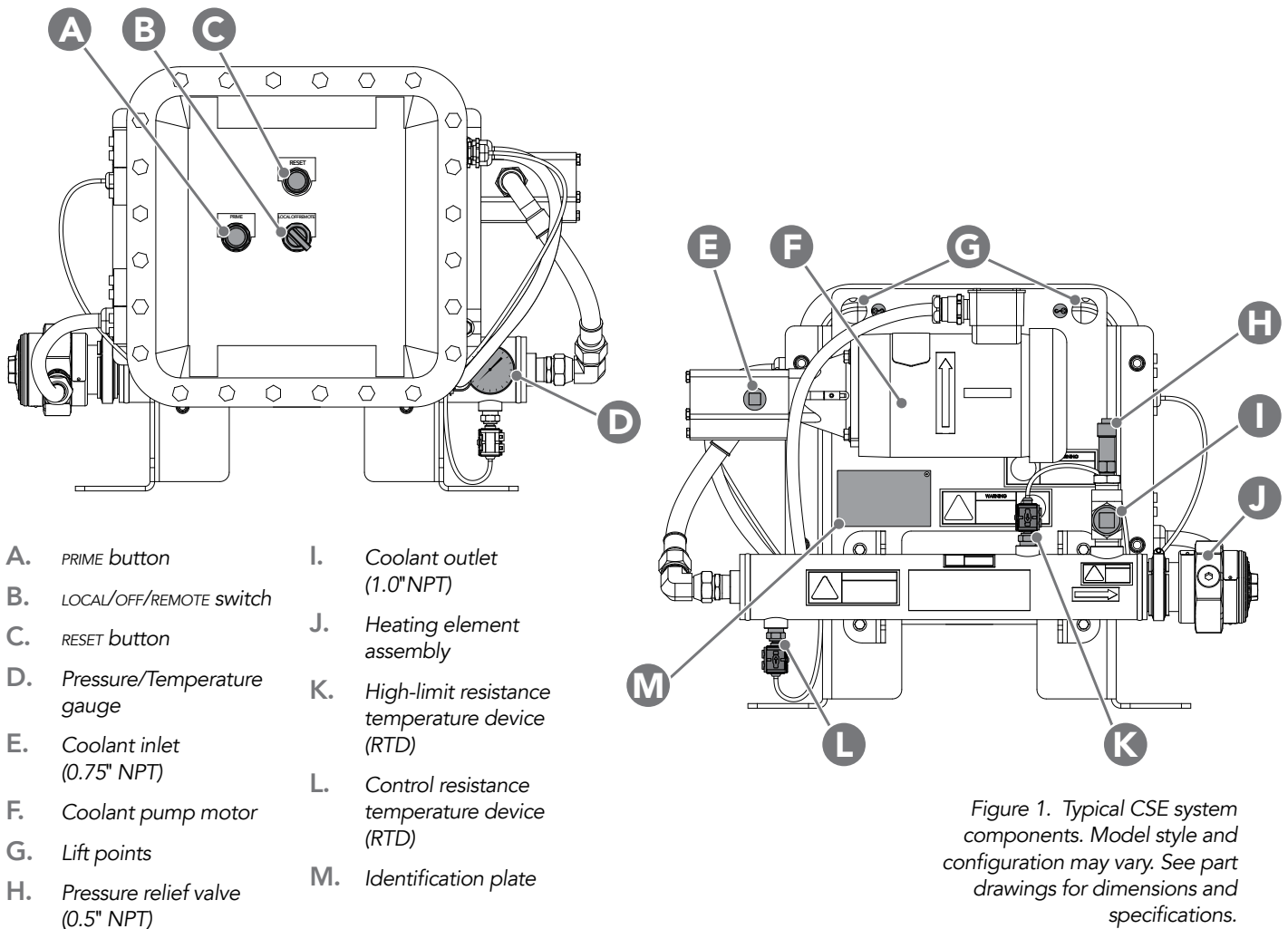

Figure 1. Typical CSE system components. Model style and configuration may vary. See part drawings for dimensions and specifications.

1.2 OPERATION OVERVIEW

The CSE heating system is intended to maintain an engine's optimal starting temperature while the engine is shut down. The CSE heating system must be deactivated upon engine start-up. (see **SECTION 2.4.3**).

During heating system operation, a positive displacement pump takes coolant from the water jacket and forces it through the heating tank to the coolant return line. The coolant pump will continuously circulate fluid throughout the engine. To maintain consistent fluid temperature, the heating element will cycle on and off at the user-selected temperature control point.

When the engine is shut down, the heating system should be activated locally or remotely to resume maintaining the engine's optimal starting temperature.

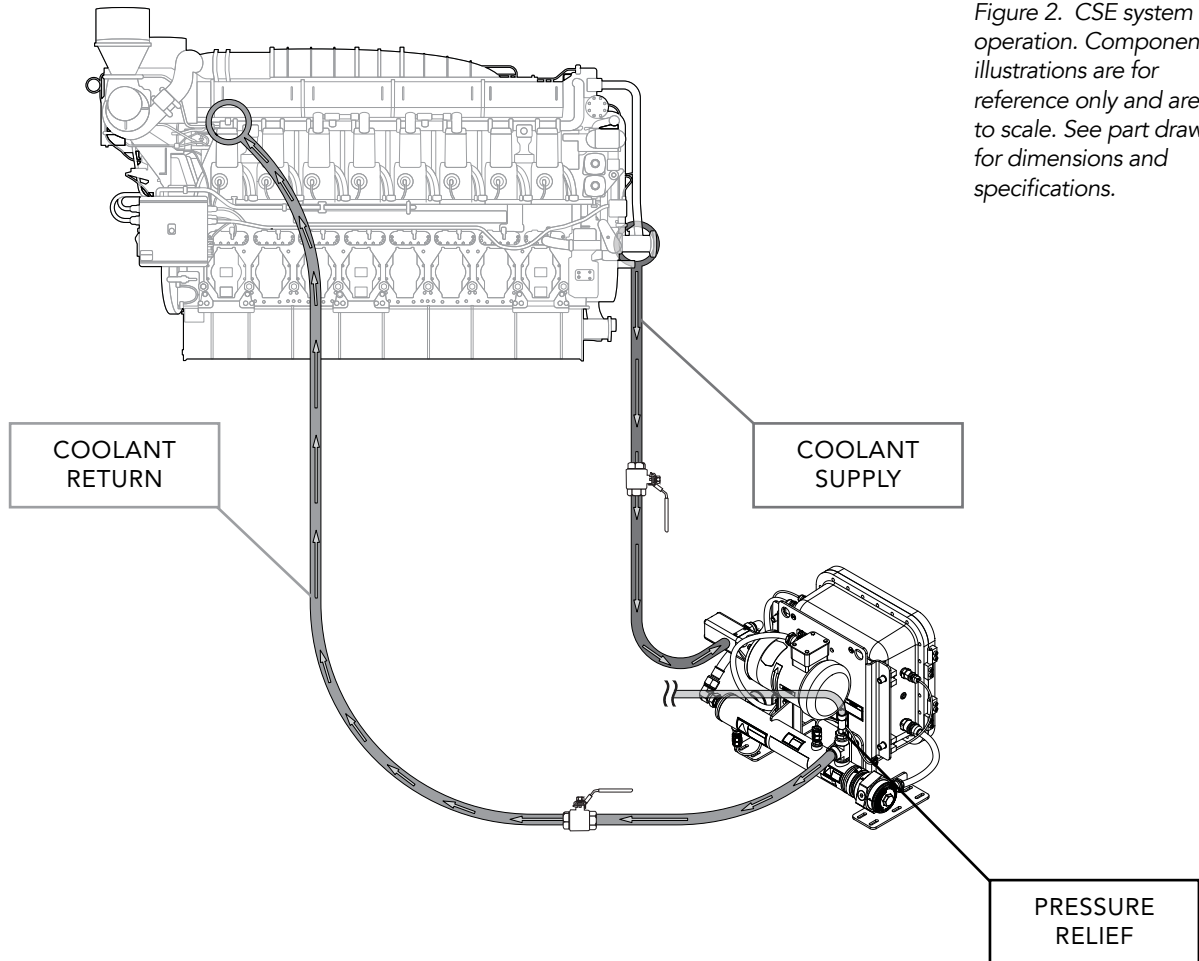

Figure 2. CSE system operation. Component illustrations are for reference only and are not to scale. See part drawings for dimensions and specifications.

2 INSTALLATION

CAUTION

Pressure hazard: Power must be turned off and locked out at the service panel when the isolation valves are in the closed position. Failure to do so may cause damage to heating system components, damage to coolant, leaks and unexpected release of heated coolant.

Overheating hazard: After completing line installation, top off the fluid levels to compensate for the fluid used to fill the lines and heating tank. Do not operate the heating system without the presence of fluid. Position the heating tank to ensure it is completely full of fluid while in operation.

Pump priming: Fill supply line with fluid. Pump is not self-priming. Fluid must be present in the pump before start-up. Trapped air inside the pump will cause pump and seal damage.

Pump seal damage: Do not reduce the coolant supply line to an inner diameter smaller than the pump inlet; pump seal damage could occur.

Isolation valves: HOTSTART recommends installing full-flow ball valves to isolate the heating system in order to perform service on the system or engine without draining the coolant.

Pressurized steam hazard: Coolant pressure relief valve outlet must be plumbed to a safe area in case an over-pressure release of heated coolant occurs.

Heating system damage: Engine vibration will damage the heating system; isolate the heating system from vibration. Never mount the heating system or components directly to the engine. If the heating system is installed using rigid pipe, use a section of flexible hose to the supply and return ports to isolate the heating system from engine vibration.

2.1 COOLANT PLUMBING INSTALLATION

NOTICE

Pump rotation (three-phase only): For three-phase applications, check for proper pump rotation prior to introducing fluid to the pump (see **SECTION 2.4.2**). Reverse rotation while the pump is filled with fluid will cause pump seal failure.

Maximum discharge pressure: The maximum discharge pressure of the CSE is 30 psi. If the pressure gauge indicates a higher pressure during heater operation, the inner diameter of the coolant return plumbing, including line and port, must be increased. Failure to increase the coolant return plumbing inner diameter will result in nuisance trips of the motor protection switch and may cause heater damage.

2.1.1 COOLANT SUPPLY

When installing the CSE coolant supply line, refer to the following HOTSTART guidelines:

- At a minimum, size the coolant supply line per the pump inlet. **NOTICE!** Do not reduce the supply line inner diameter; pump seal damage will occur.
 - NOTE:** To maximize flow and allow the longest possible supply line, install the largest practical inner diameter hose; for most installations, HOTSTART recommends using a hose with a size larger inner diameter than the pump inlet.
- Install the coolant suction port as low as possible on the engine's water jacket.
- To minimize flow restriction, the coolant supply line must be as short and as straight as possible. Use elbow fittings sparingly; HOTSTART recommends using sweeping bends or 45° fittings.

2.1.2 COOLANT RETURN

When installing the CSE coolant return line, refer to the following HOTSTART guidelines:

- Size the coolant return line per the coolant outlet. **NOTICE!** Do not reduce the return line inner diameter.
- Install the coolant discharge port as high as possible on the engine's water jacket at the end of the engine opposite the suction port, typically at the rear of the engine block.

2.1.3 COOLANT PRESSURE RELIEF

- To safeguard personnel and equipment, attach an appropriately-sized pipe to the pressure relief valve and route to a safe area, bucket or catch-basin. **CAUTION!** Coolant pressure relief valve outlet must be plumbed to a safe area in case an over-pressure release of heated coolant occurs. Do not connect pressure relief plumbing to coolant system.

2.2 MOUNTING

CAUTION

Lifting hazard: Proper rigging and safety equipment must be used to move this equipment. Do not lift the heating system by any cords, electrical conduit or cabling. Create a plan before attempting to move. Proper lifting locations are identified on each system; use these locations when lifting and mounting the system.

Overheating hazard: When mounting the heating tank, position the tank so that it is completely full of fluid while in operation.

NOTICE

Heating system damage: Engine vibration will damage the heating system; isolate the heating system from vibration. Never mount the heating system or components directly to the engine.

Improper mounting hazard: Reference heating system component drawings before mounting the system. Unless mounted properly, the heating system will be unstable.

2.2.1 TANK AND PUMP

Mount the heater in a vertical orientation with pump motor assembly directly above tank. Reference drawings for mounting position. When installing the heating system, note that the tank requires a minimum of 18 inches (46 cm) of clearance to remove element for maintenance. See **SECTION 4.2.11**.

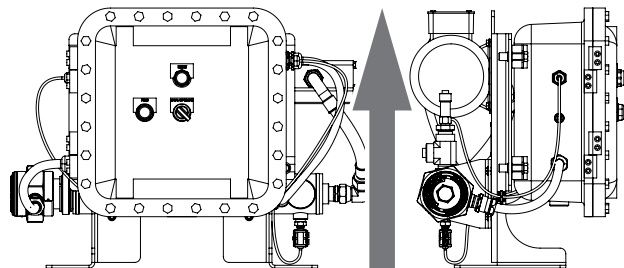
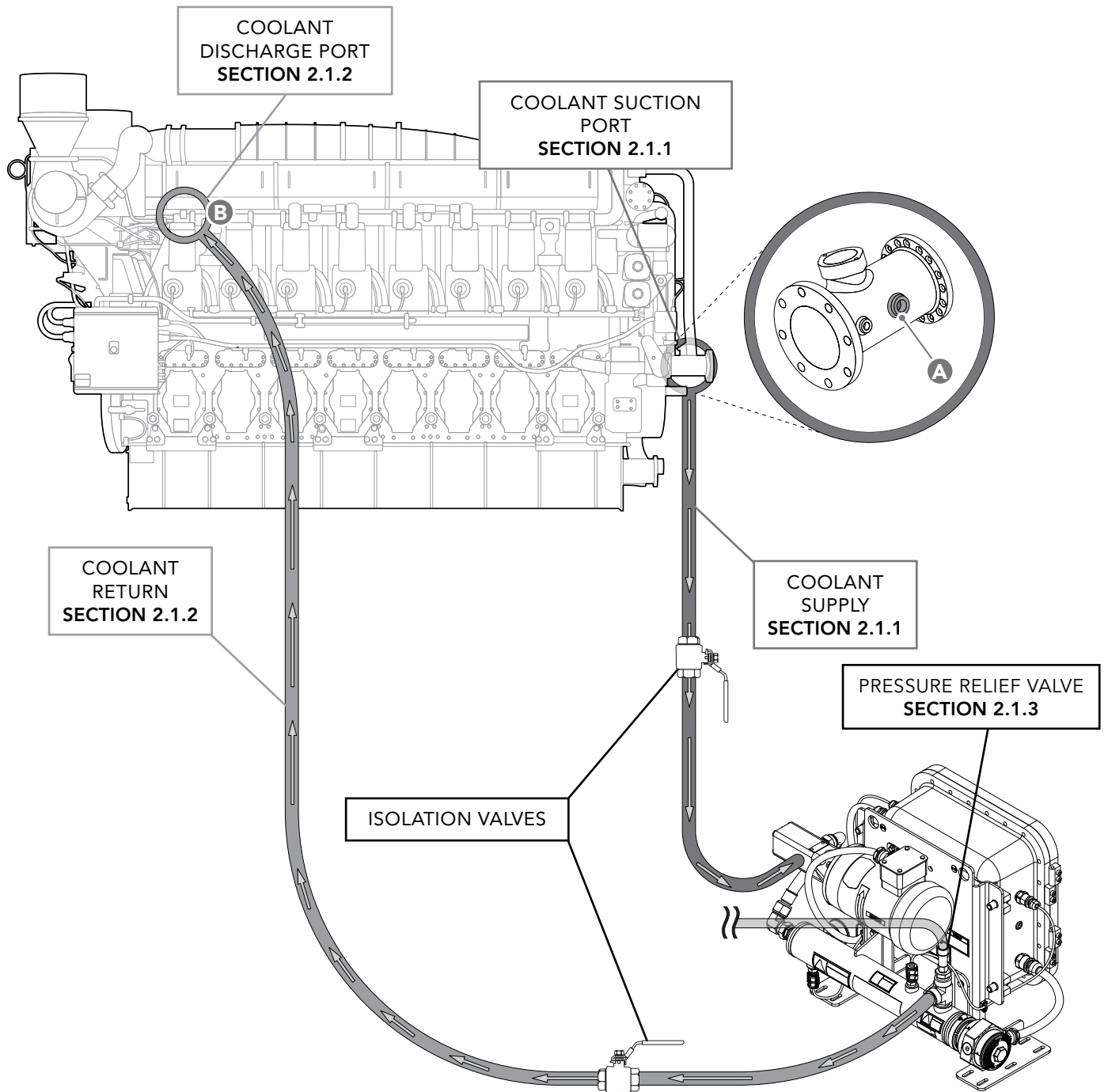
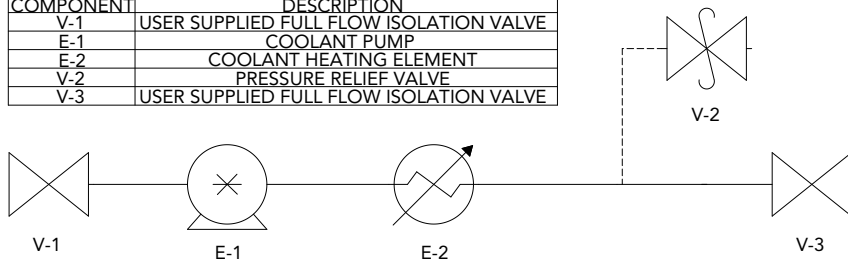

Figure 3. Mount CSE unit in orientation shown. Do not mount at an angle or in any other orientation.

2.3 COOLANT PLUMBING ILLUSTRATION



COMPONENT	DESCRIPTION
V-1	USER SUPPLIED FULL FLOW ISOLATION VALVE
E-1	COOLANT PUMP
E-2	COOLANT HEATING ELEMENT
V-2	PRESSURE RELIEF VALVE
V-3	USER SUPPLIED FULL FLOW ISOLATION VALVE



2.4 ELECTRICAL CONNECTIONS

2.4.2 MOTOR ROTATION CHECK



Hazardous voltage: Before wiring, servicing or cleaning the heating system, turn off the power and follow your organization's lockout and tagout procedure. Failure to do so could allow others to turn on the power unexpectedly, resulting in harmful or fatal electrical shock.

Electrical hazard: All wiring shall be done by qualified personnel in accordance with national, state and local codes. Each system shall be grounded in accordance with the National Electrical Code. Failure to properly ground the system may result in electrical shock.

2.4.1 MAIN POWER SUPPLY

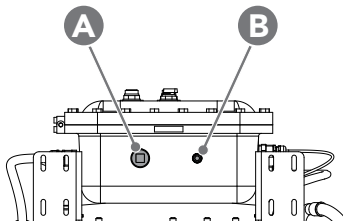

Figure 4. CSE control box underside, showing 1.25" NPT main power entrance (A) and 0.5" NPT customer interface wiring entrance (B).

1. Connect the specified power from the customer-supplied circuit breaker to the terminal blocks located in the main control box. See Figure 5 on following page.
 - NOTE:** The specified power source must be within plus or minus 10% of the rated voltage.
 - NOTE:** The circuit breaker must be near the heating system and easily accessible. HOTSTART recommends connecting the heating system to a circuit breaker rated for 125% of the system's maximum load.
 - NOTE:** The main power supply operates the heating elements and the circulating pumps. A transformer is used to operate the control circuit. The transformer and control circuits are overload-protected.
 - For **three-phase applications**, the terminal blocks are labeled **L1, L2 and L3 (A)**.
 - For **single-phase applications**, use the terminal blocks labeled **L1 and L2 or L and N (A)**.
2. Connect the main power ground wire to the ground block (B).

NOTICE

Pump rotation (three-phase only): For three-phase applications, check for proper pump rotation prior to introducing fluid to the pump. Reverse rotation while the pump is filled with fluid will cause pump seal failure.

Pump damage: Do not run the motor/pump assembly dry for more than a few seconds. Running a motor/pump for a prolonged period without being completely filled with fluid may cause damage to the pump seal.

The following procedures are for three-phase applications only. Single-phase systems are prewired to ensure the pump motor rotates in the correct direction.

1. With main power connected to the heating system motor (see SECTION 2.4.1), energize the pump while observing the rotation of the pump motor fan at the rear of the motor. Refer to rotation decal on motor for correct rotation.
 - If the pump motor does not rotate in the correct direction, disconnect power and switch any two electrical leads at the main power terminal block (**L1, L2, L3**). Reconnect power. Repeat step 1 to ensure motor rotates in the correct direction.

2.4.3 CUSTOMER INTERFACE CONNECTIONS

The following customer interface connections are available for remote control and monitoring (See Figure 5 on following page):

- **TB2:1/TB2:2 Remote On/Off 24 V DC shutdown (C)**
When activated, the remote on/off connection shuts down the heating system. When deactivated, normal heating will resume. Use this connection for remote operation of the heater when the **LOCAL/OFF/REMOTE** switch is turned to **REMOTE**.

NOTE: The **24 V DC shutdown** connection is wired **NC (normally closed)** from the factory; see system wiring schematic for directions to switch to **NO (normally open)** operation.

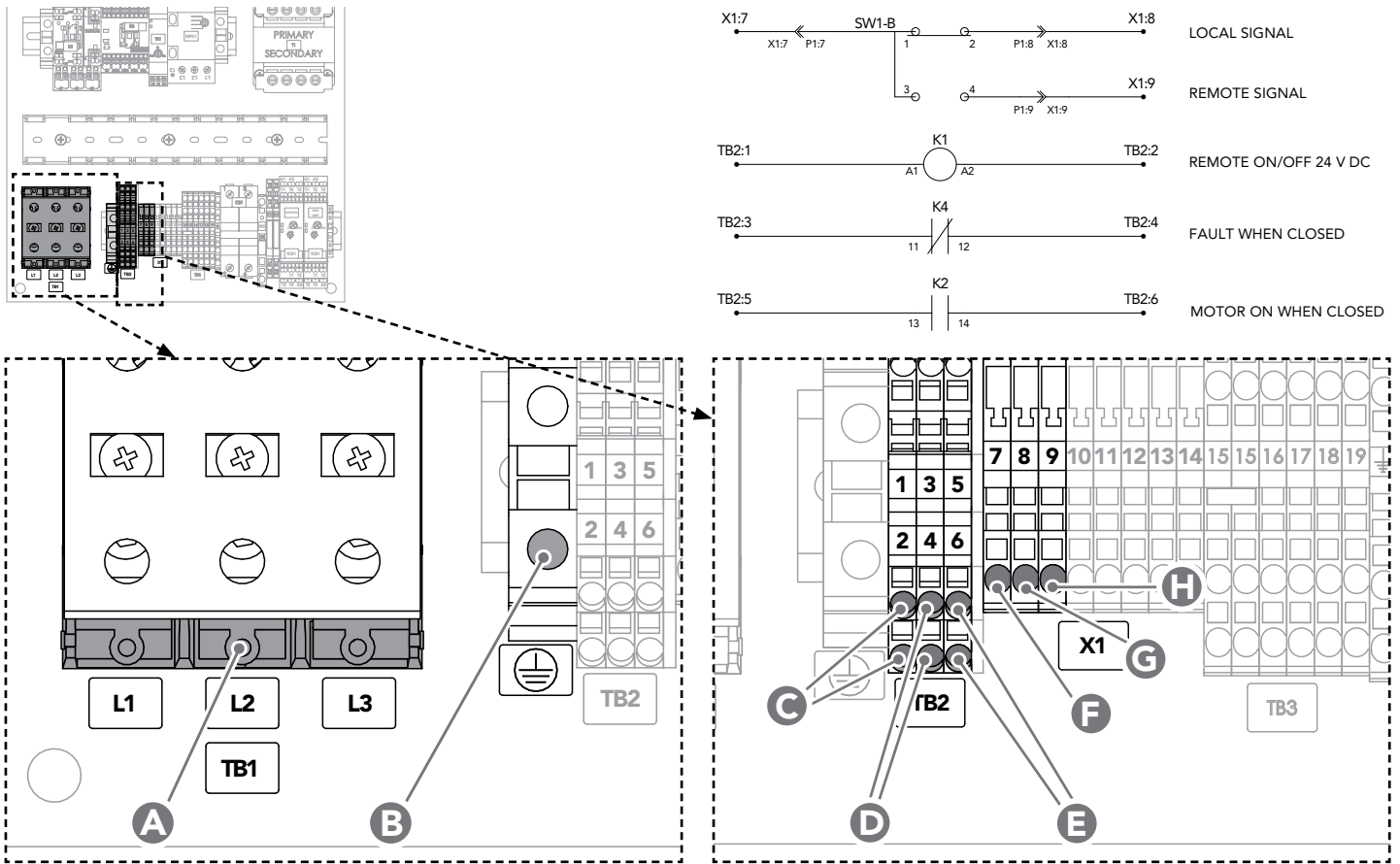

- | | |
|-----------------------------------|------------------------------------|
| A. Main power terminal block | E. Motor run signal |
| B. Main power ground block | F. Switch location signal (off) |
| C. Remote On/Off 24 V DC shutdown | G. Switch location signal (local) |
| D. Fault signal | H. Switch location signal (remote) |

- TB2:3/TB2:4 Fault Signal (D)**
 The fault signal will indicate a heating system shutdown, triggered by either the high-limit temperature control relay or the motor protection switch (see **SECTION 4.1.1**)
- TB2:5/TB2:6 Motor Run Signal (E)**
 A motor run signal indicates the pump motor is running. If no signal is present, the pump motor is not running.
- X1:7/X1:8/X1:9 Switch Location Signal (F, G, H)**
 The switch location signal indicates the **LOCAL/OFF/REMOTE** switch position: **OFF (F), LOCAL (G) or REMOTE (H)**.

Figure 5. Main power supply and customer interface connections as shown in the CSE control box. Reference electrical schematic drawing for proper wiring locations; the following illustrations are typical customer interface locations.

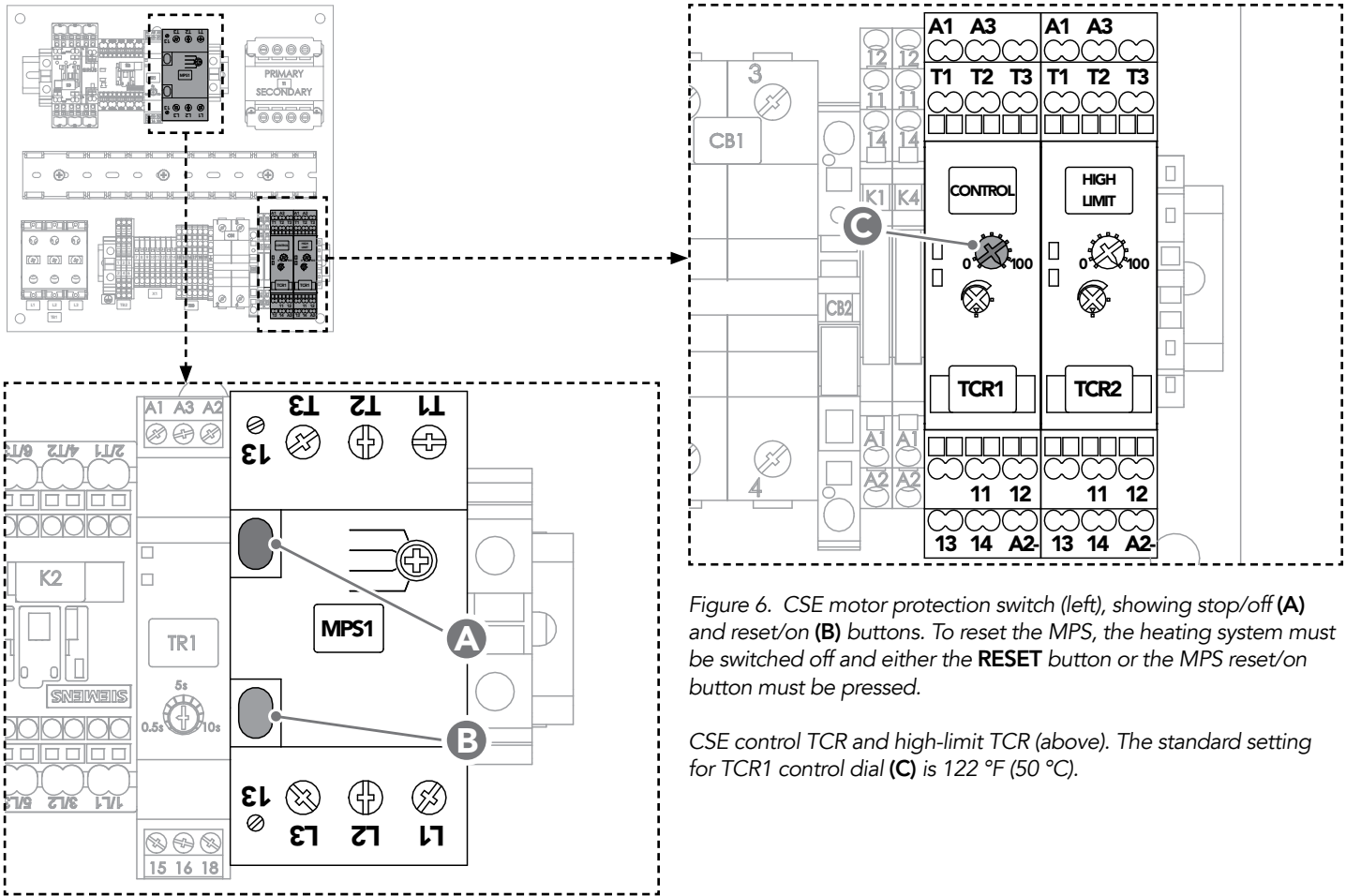

Figure 6. CSE motor protection switch (left), showing stop/off (A) and reset/on (B) buttons. To reset the MPS, the heating system must be switched off and either the **RESET** button or the MPS reset/on button must be pressed.

CSE control TCR and high-limit TCR (above). The standard setting for TCR1 control dial (C) is 122 °F (50 °C).

3 COMPONENTS AND OPERATION

The following is an operational description for each of the CSE interface and system components.

NOTE: Components installed in control box may vary depending on the particular system configuration purchased.

3.1 SYSTEM COMPONENTS

3.1.1 MOTOR PROTECTION SWITCH

The motor protection switch (MPS) protects the pump motor from overloads. The MPS will be set at the full load amperage of the motor when shipped from the factory. To reset the MPS, the **LOCAL/OFF/REMOTE** switch must be switched to **OFF** and the operator must press the **RESET** button or press the MPS reset/on button (B). See Figure 6. For additional troubleshooting, see **SECTION 4.5**.

3.1.2 CONTROL TCR (TEMPERATURE CONTROL RELAY)

The control TCR is used to control the temperature of the fluid. The control TCR uses a resistance temperature device (RTD) to sense the temperature of the fluid as it enters the heater. The standard setting for the control temperature relay (TCR1) is 122 °F (50 °C). See Figure 6.

3.1.3 HIGH-LIMIT TCR (TEMPERATURE CONTROL RELAY)

The high-limit TCR (TCR2) is a protection device to prevent fluid overheating. The high-limit TCR uses a resistance temperature device (RTD) located near the tank outlet. The default setting for the high-limit TCR is 194 °F (90 °C) and should always be at least 18 °F (10 °C) higher than the control TCR set point. The high-limit TCR hysteresis is not used in the high-limit control. See Figure 6.

3.2 INTERFACE COMPONENTS

3.2.1 LOCAL/OFF/REMOTE SWITCH

- **LOCAL** – The system is **on**.
- **OFF** – The system is shut **off**.
- **REMOTE** – The system will turn on and shut off on a signal from the 24 V DC remote connection. See **SECTION 2.4.3**.

3.2.2 PRIME BUTTON

Press and hold the **PRIME** button to energize the pump motor in order to remove any air in the heating system without energizing the elements. **NOTICE!** Do not run the motor/pump assembly dry for more than five seconds at a time.

NOTE: The **PRIME** function is intended for use during the first run procedure (see **SECTION 3.3.1**) or after performing maintenance on the heating system or plumbing (see **SECTION 4.3**).

3.2.3 RESET BUTTON

Press the **RESET** button to reset the pump motor protection switch without opening the control box. The reset function is intended for use immediately following resolving and repairing a system fault (see **SECTION 4.1.1**).

3.2.4 PRESSURE/TEMPERATURE GAUGE

The CSE model features a temperature/pressure gauge mounted at the inlet of each heating tank. The gauge will indicate a pressure increase when the pump motor is engaged by pressing and holding the **PRIME** button or during normal operation. The gauge will also indicate the current temperature of the respective fluid.

NOTE: Your system's operating pressure may vary depending on the configuration of the engine.

3.2.5 PRESSURE RELIEF VALVE



Pressurized steam hazard: Coolant pressure relief valve outlet must be plumbed to a safe area in case an over-pressure release of heated coolant occurs.

The coolant pressure relief valve is mounted at the coolant heating tank outlet and is set to relieve at 100 psi (690 kPa). During normal operation, pressure release

events are rare. To safeguard personnel and equipment, attach an appropriately sized pipe to the pressure relief valve outlet and direct flow to a safe area, bucket or other catch-basin.

3.3 HEATING SYSTEM START-UP



Hazardous voltage: Before wiring, servicing or cleaning the heating system, turn off the power and follow your organization's lockout and tagout procedure. Failure to do so could allow others to turn on the power unexpectedly, resulting in harmful or fatal electrical shock.

NOTICE

Pump damage: Do not run the motor/pump assembly dry for more than five seconds at a time. Running a pump that is not completely filled with fluid will cause damage to the pump seal.

Proper heating operation: The high-limit temperature control relay (TCR2) must be set at least 18 °F (10 °C) higher than the control temperature control relay (TCR1) for proper heating operation. This will prevent nuisance tripping of the high-limit circuit.

3.3.1 FIRST RUN PROCEDURE

1. For three-phase applications, ensure a motor rotation check has been performed prior to introducing fluid to the pumps (see **SECTION 2.4.2**).

NOTE: Single-phase systems are prewired to ensure the pump motor rotates in the correct direction. A motor rotation check is not necessary.

2. Check and tighten all electrical and plumbing connections.
3. Ensure isolation valves are **open** before energizing the system.
4. Bleed all trapped air from the heating system by opening a plug or pipe fitting at or near the pump. Press and hold the **PRIME** button to evacuate any remaining air in the lines.

NOTE: When priming the pump, the pressure gauge should indicate an increase in pressure. Your system's operating pressure may vary depending on the configuration of the engine.

5. Turn the **LOCAL/OFF/REMOTE** switch to **LOCAL** or **REMOTE** to energize the heating system.
6. Once operation is satisfactory, turn the control dial on the temperature control relay TCR1 to the desired temperature setting for engine oil. HOTSTART recommends a control temperature on TCR1 of 104 °F (40 °C). The high-limit temperature setting on TCR2 should be set at 194 °F (90 °C). See **SECTION 3.1.2** and **SECTION 3.1.3**.
7. Turn the **LOCAL/OFF/REMOTE** switch to **REMOTE** to verify the 24 V DC remote signal connection (if installed).

4 MAINTENANCE, REPAIR AND TROUBLESHOOTING

4.1 SYSTEM FAULTS

4.1.1 COOLANT FAULTS

A fault signal will be transmitted if:

- The coolant pump motor protection switch is tripped (MPS1).
- The coolant high-limit temperature is exceeded (TCR2).

A failure in the pump motor that causes the motor protection switch (MPS1) to trip will shut down the heating system. A fault signal will be transmitted. If this failure occurs, the **LOCAL/OFF/REMOTE** switch must be switched to **OFF** and the operator must press the **RESET** button (or the MPS reset/on button) to reset the fault. (See **SECTION 3.2.3**.)

If there is a failure that causes a high temperature to occur, the high-limit temperature controller (TCR2) will shut down the heating system, including the pump motor. A fault signal will be transmitted. To restart the system, the **LOCAL/OFF/REMOTE** switch must be switched to **OFF** and then back to **LOCAL** or **REMOTE** to resume operation once the fluid temperature drops below the high-limit preset (See **SECTION 3.1.3**.)

For additional troubleshooting, see **SECTION 4.5**.

4.2 SYSTEM MAINTENANCE



Hazardous voltage: Before wiring, servicing or cleaning the heating system, turn off the power and follow your organization's lockout and tagout procedure. Failure to do so could allow others to turn on the power unexpectedly, resulting in harmful or fatal electrical shock.

Instructions for the following maintenance procedures are provided to ensure trouble-free operation of your heating system. Replacement parts must meet or exceed original part requirements in order to maintain the compliance level of the original heating system.

NOTE: After maintenance is performed, refer to **SECTION 3.3.1** for system start-up procedures.

4.2.1 PLUMBING CONNECTIONS

Periodically check plumbing connections for leaks and, if necessary, tighten connections. A loose connection on the suction side will cause a loss of flow and cavitation in the pump. It can also pull air into the heating tank and cause an element failure.

4.2.2 ELECTRICAL CONNECTIONS

Vibration may cause terminals to loosen. At start-up, tighten electrical connections. Check connections again in a week. Tighten all electrical connections every three months.

4.2.3 SYSTEM MOUNTING

Vibration may cause mounting bolts to loosen. Periodically check and tighten all mounting bolts.

4.2.4 MAGNETIC CONTACTORS

Magnetic contactors are used as voltage switching controls for motors and heating elements in HOTSTART heating systems. The contactors use 120 volt or 240 volt coils. To test for failure, check for continuity across the coil connections; an open or direct-short reading indicates a failed contactor coil.

The contacts on the magnetic contactor should be inspected periodically for welding, arc erosion and mechanical wear. If any of these conditions exist, replace the magnetic contactor. HOTSTART recommends contactors be replaced every five years.

4.2.5 PUMP SEAL

If seal becomes worn, replacement pump seals are available. To ensure pump seal longevity, ensure the supply lines do not restrict flow excessively (see **SECTION 2.1.1**)

NOTE: Instructions to replace the pump seals are included with replacement seals.

4.2.6 PRESSURE RELIEF VALVE

The pressure relief valve on coolant systems must be periodically checked and replaced when appropriate. At a minimum, the valve should be removed from the system, checked for deposits and corrosion, and tested to ensure that it relieves the proper pressure.

4.2.7 PRESSURE/ TEMPERATURE GAUGE

The coolant pressure/temperature gauge will indicate a pressure increase when the pump motor is engaged by pressing the **PRIME** button or during normal heater operation. The gauge will also indicate the current fluid temperature. No maintenance for this part is required.

4.2.8 VOLATILE CORROSION INHIBITOR

A volatile corrosion inhibitor (VCI) is provided with each control box and should be replaced once a year.

NOTE: Heating systems placed in extended storage will require that the VCI is replaced at six month intervals. See **SECTION 4.3**.

4.2.9 TEMPERATURE CONTROL RELAY



Hazardous voltage: Before wiring, servicing or cleaning the heating system, turn off the power and follow your organization's lockout and tagout procedure. Failure to do so could allow others to turn on the power unexpectedly, resulting in harmful or fatal electrical shock.

If the CSE heating system does not maintain the desired preset control temperature or signals a high-limit temperature fault immediately upon system start-up, the TCR (temperature control relay), the RTD (resistance temperature device), or the RTD cable may require replacement. To perform this troubleshooting, you will need:

- Ohmmeter
1. De-energize the heating system. Verify fluid is present and flow is not restricted. Check temperature gauge to ensure the liquid in the tank is below 122 °F (50 °C).
 2. Verify the control TCR (TCR1) is set correctly. Verify that high-limit TCR (TCR2) is set at least 18 °F (10 °C) higher than the control TCR set point. If the measured resistance is **between 80 and 120 ohms** continue troubleshooting. *Proceed to step 3.*
 3. Using the ohmmeter, measure the resistance between TCR terminals **T1** and **T2** (See Figure 7):
 - If the measured resistance is **between 80 and 120 ohms** continue troubleshooting. *Proceed to step 4.*
 - If the resistance is **lower than 80 ohms** or **higher than 120 ohms**, contact HOTSTART for further assistance.
 4. Using the ohmmeter, test for continuity between TCR terminals **T2** and **T3**:
 - If there **is continuity** between TCR terminals **T2** and **T3**, the TCR, RTD and RTD cable are functioning correctly. Close control panel. Allow fluid to cool below high-limit preset temperature. Perform system start-up (see **SECTION 3.3.1**). If fault or temperature problems persist after start-up, contact HOTSTART for further assistance.
 - If there **is no continuity** between TCR terminals **T2** and **T3**, locate connected RTD on the heating tank. Unscrew the RTD plug from RTD. See Figure 9 and Figure 10 on following page.

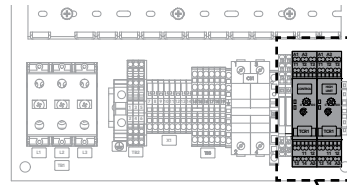
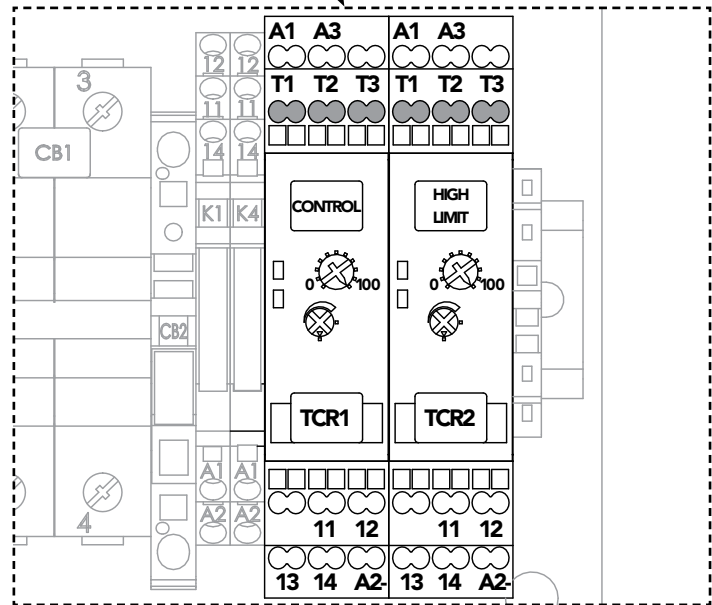

Figure 7. Control (TCR1) and high-limit (TCR2) TCR showing terminals T1, T2 and T3.



5. Using the ohmmeter, touch the probes to RTD **pin 1** and **pin 3**. See Figure 8. Note the resistance. Touch the probes to RTD **pin 1** and **pin 4** to check for continuity:
 - If the resistance between RTD **pin 1** and **pin 3** is **between 80 and 120 ohms** and there **is continuity** between RTD **pin 1** and **pin 4**, the RTD is functioning properly. Replace the RTD cable.
 - If the resistance between RTD **pin 1** and **pin 3** is **not between 80 and 120 ohms** or there is **no continuity** between **pin 1** and **pin 4**, the RTD is malfunctioning. Replace the RTD. See **SECTION 4.2.10**.

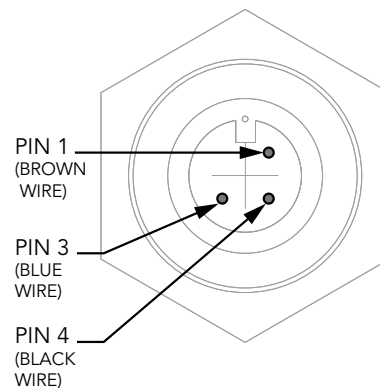

Figure 8. RTD pins 1, 3 and 4. The resistance between pin 1 and pin 3 should measure between 80 and 120 ohms. There should be continuity between pin 1 and pin 4.

4.2.10 CONTROL RESISTANCE TEMPERATURE DEVICE (RTD)



Hazardous voltage: Before wiring, servicing or cleaning the heating system, turn off the power and follow your organization's lockout and tagout procedure. Failure to do so could allow others to turn on the power unexpectedly, resulting in harmful or fatal electrical shock.

High-limit or control resistance temperature devices (RTDs) sense temperature to either control fluid temperature or protect the system and fluid from overheating. To replace a resistance temperature device (RTD), use the following procedures.

NOTE: Before removing and replacing an RTD, ensure the RTD is malfunctioning. See **SECTION 4.2.9**.

1. De-energize the heating system. Allow fluid to cool.
2. Close isolation valves. Drain the fluid from the oil or coolant heating tank. Locate the control RTD **(A)** or high-limit RTD **(B)** that requires replacement. See *Figure 9*.
3. Insert small flat-head screwdriver into RTD lockout guard latch. See *Figure 10*. Rotate screwdriver to release latch. Remove RTD lockout guard **(E)**.
4. Pull RTD plug to remove plug **(D)**
5. Unscrew RTD **(C)** from tank.
6. Screw replacement RTD to tank.
7. Fit RTD plug to RTD. Push plug in firmly. Place lockout guard over plug and RTD. Ensure guard arrow points toward tank. Close guard and snap latch firmly to secure.
8. To ensure proper installation and temperature regulation, re-energize and operate heating system. Refer to **SECTION 3.3.1** for system start-up procedures.

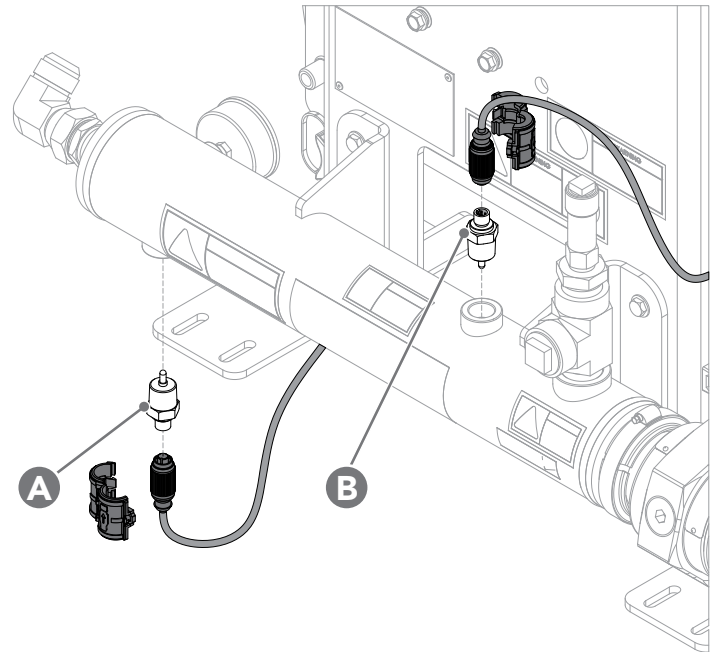

*Figure 9. CSE control RTD **(A)** and high-limit RTD **(B)**, showing RTD **(C)**, RTD plug **(D)** and RTD lockout guard **(E)**.*

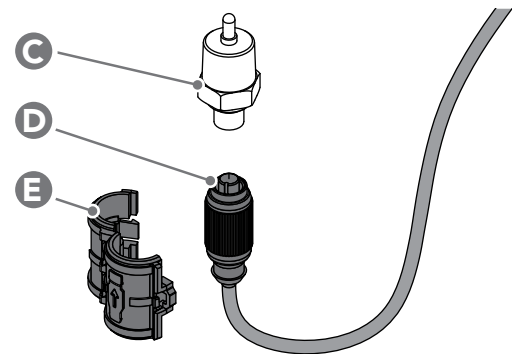
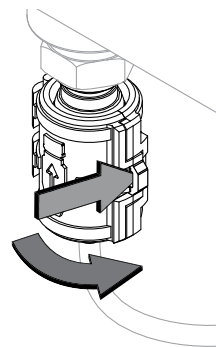

Figure 10. Removing lockout guard. Insert flat-head screwdriver into latch. Rotate screwdriver to release latch.



4.2.11 HEATING TANK/ELEMENTS



Hazardous voltage: Before wiring, servicing or cleaning the heating system, turn off the power and follow your organization's lockout and tagout procedure. Failure to do so could allow others to turn on the power unexpectedly, resulting in harmful or fatal electrical shock.

At least once per year, clean the interior of the heating tank and the heating element with a wire brush and/or damp cloth. Periodically check the sediment build-up around the element loops. Any scaling or build-up will shorten element life.

To replace the heating element or perform routine maintenance, use the following procedures. See *Figure 11*. The wattage and phase of the heating element are listed on the identification plate on the outside of the element **(B)**. Reference this label for the replacement part number.

1. De-energize the heating system. Allow fluid to cool.
2. Close isolation valves.
3. Drain the fluid from the heating tank **(F)**.
4. Remove the cap **(A)** from the heating element service entrance enclosure.
5. The wire connections inside the enclosure correspond to one of the phase configurations shown on the following page. Note your unit's phase configuration. See *Figure 13*.

NOTE: Replacement elements may be a different phase configuration.

6. Disconnect the ground (green/yellow) and power electrical wires from the posts inside the cap.
7. Unscrew cable gland from conduit connector entrance **(C)**. Remove element conduit **(H)** and wires from the heating element. See *Figure 12*.
8. Loosen V-clamp screw to remove V-clamp **(D)**. Detach the heating element from the tank as shown.

9. Replace the heating element **(G)** or perform the necessary cleaning procedure. Ensure the O-ring **(E)** is in place.

4.2.12 REASSEMBLY OF HEATING ELEMENT AND TANK

To reassemble the heating element and tank, follow the steps listed in **SECTION 4.2.11** in **reverse order**. Make sure the ground and power electrical wires are properly reconnected using the provided washers, cup washers and nuts.

Figure 11. Removing and replacing the heating tank element. The heating system should be drained, cleaned and flushed annually. See SECTION 4.3.

- A. Element service entrance cap
- B. Element identification plate
- C. Conduit connector entrance
- D. V-clamp
- E. O-ring
- F. Tank
- G. Element

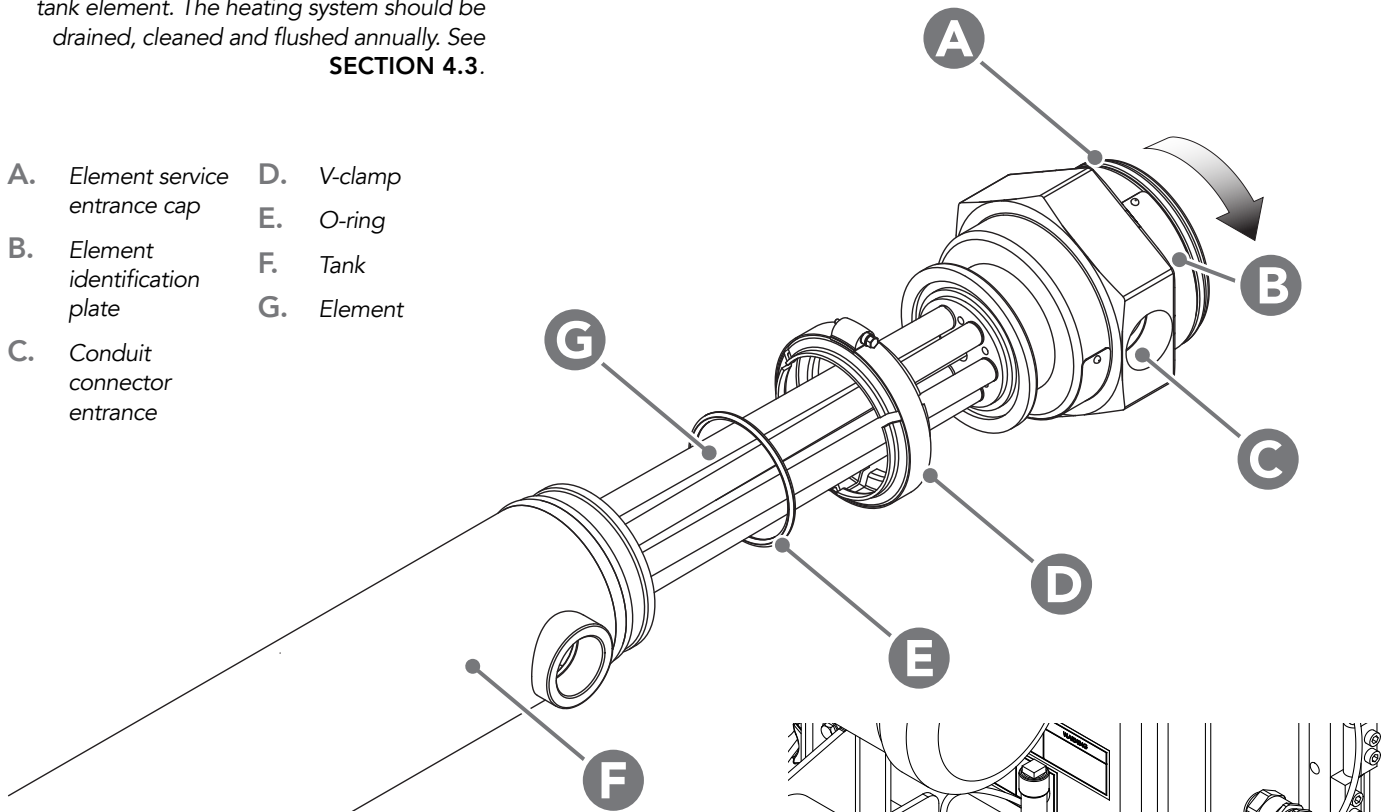

Figure 12. CSE, showing element conduit (H).

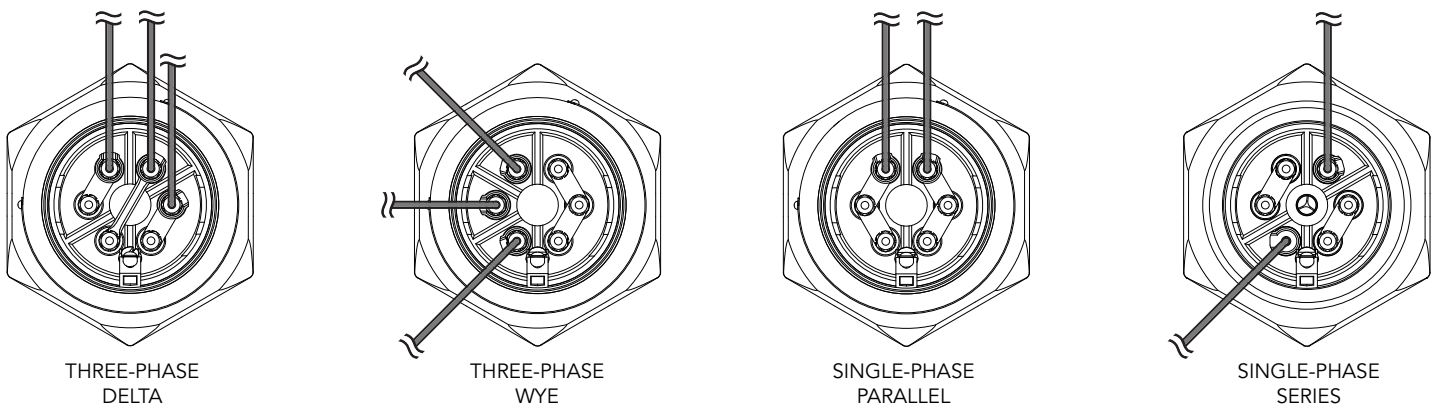
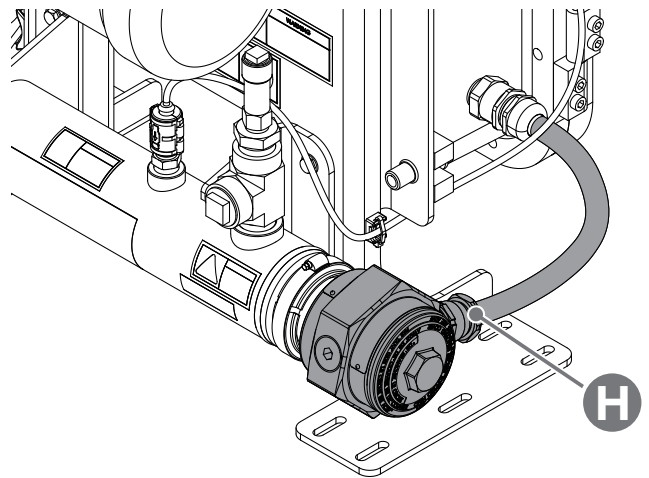

Figure 13. Heating tank element phase configurations. Replacement elements may be a different phase configuration.

4.3 RECOMMENDED MAINTENANCE

INTERVAL	MAINTENANCE TASK
At initial start-up	Tighten electrical connections. See SECTION 4.2.2.
One week after initial start-up	Check and tighten electrical connections. See SECTION 4.2.2.
Every three months	Tighten electrical connections.
Annually	Drain, clean and flush heating system.
	Check for cracked or weakened hoses and replace if necessary.
	Check electrical wiring and connections for wear and excessive heat.
	Check mounting bolts and tighten if necessary.
	Remove element and clean element and tank. See SECTION 4.2.11.
Every five years	Replace magnetic contactors. See SECTION 4.2.4.

4.4 STORAGE REQUIREMENTS

If long-term storage is necessary, precautions must be taken to ensure that the heating system is operational for start-up. Steps must be taken to ensure that water ingress is mitigated at all locations. All plugs and caps must remain tight and a suitable cover must be provided for the system. The cover must shield the system from direct rain and protect from any directed spray that may occur.

For any storage longer than three months, desiccant bags must be placed next to the system if it is still in the original packaging and inside the control box. If the storage duration will be one year or longer, the volatile corrosion inhibitor inside the control box must be replaced at six month intervals.

New pump motors placed in long-term storage for a year or longer may require relubrication before initial use. If your pump motor has provisions for relubrication, refer to the pump motor manufacturer's relubrication recommendations. Refer to the pump motor nameplate for lubrication type.

4.5 TROUBLESHOOTING

SYMPTOM	POSSIBLE CAUSES	SOLUTION
Coolant system fault	Pump not primed properly	Bleed all trapped air from lines. Restart system.
	Isolation valves may be closed	Open valves. Restart system.
	Hose kinked or crushed	Remove obstruction. Restart system.
	Leak in suction line	Repair leak. Restart system.
	Pump motor turning backwards	Reverse any two leads on power (in three-phase system). Restart system. See SECTION 3.3.1 .
	Control TCR failure: closed	Check and replace if necessary. See SECTION 4.2.9 .
	Motor failure	Check and replace if necessary. Restart system.
	Motor contactor failure	Check contacts and replace if needed. Restart system.
	Motor protection switch tripped	Check and reset switch. If problem occurs again, check motor. Restart system.
	RTD failure	Check TCR and RTD. See SECTION 4.2.9 .
	RTD cable failure	Check TCR and RTD. See SECTION 4.2.9 .
Coolant temperature too low	Motor failure	Check motor. Replace if necessary.
	Heater has been turned off and fluid is cold	Allow time for the heating system to heat fluid.
	Heating element failed	Check elements for continuity. Replace element if necessary.
	Element breaker tripped	Check for element short to ground. If no short, reset breaker.
	Element contactor failed	Check contacts and coolant. Replace if necessary.
	Motor contactor failed	Check contacts and coolant. Replace if necessary.
	Control TCR failure: open	Check and replace if necessary. See SECTION 4.2.9 .
	Control TCR set point too low	Adjust set point for control TCR. See SECTION 3.2.2 .
	RTD failure	Check TCR and RTD. See SECTION 4.2.9 .
	RTD cable failure	Check TCR and RTD. See SECTION 4.2.9 .