

Hotstart Manufacturing, Inc. is the owner of all trademarks and copyrightable material contained herein; all rights are reserved; no form of reproduction is authorized without prior written consent from Hotstart Manufacturing, Inc.

INSTALLATION INSTRUCTIONS

INDUSTRIAL IMMERSION HEATERS FOR WEATHERTIGHT & HAZARDOUS LOCATIONS

BEFORE YOU INSTALL



Hazardous voltage: Before wiring, servicing or cleaning the heating system, turn off the power and follow your organization's lockout and tagout procedure. Failure to do so could allow others to turn on the power unexpectedly, resulting in harmful or fatal electrical shock.

Fire or explosion risk: If the heater element is not equipped with a high temperature limit switch or thermostat, a temperature control must be added. Uncontrolled heating may result in fire or explosion.



Personal injury: Disconnect power supply before performing any electrical work. Wiring must be performed by a trained technician and in accordance with national and local electrical codes. (Reference directive 2006/95/EC in EU countries.)

Hot surfaces: Hot surfaces are a potential injury hazard. Use caution when working on or around the heater. Allow heater to cool before removing or servicing.



Liquid level switch: On applications where level of fluid is subject to change, HOTSTART requires installing a user-supplied liquid level switch mounted a minimum of 3 to 4 inches (8 to 10 cm) above the element. An approved liquid level control must be provided as described in the caution label on the heater enclosure.

Contactors and transformers: To complete installation, single-phase heaters require a contactor if the thermostat's amperage limit is exceeded and a control transformer if the thermostat's voltage limit is exceeded. Three-phase heaters rated for up to 240 volts require a contactor; three-phase heaters rated for over 240 volts will require a contactor and transformer.

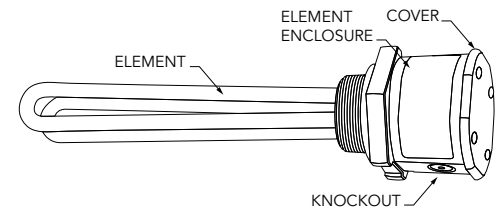
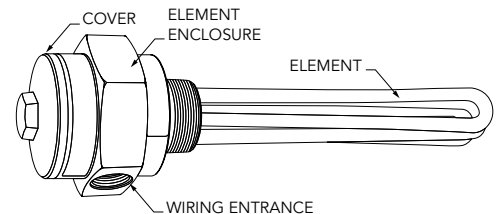

Figure 1. Typical weathertight industrial immersion heater and components (above).

Class I, Group D industrial immersion heater rated for use in hazardous locations (below).



INDUSTRIAL IMMERSION HEATERS

HOTSTART industrial immersion heaters are designated as either weathertight or for use in hazardous locations (Class I, Group D). Depending on your heater's specifications, it may connect to your equipment using threaded design or using a threadless V-clamp and weldable adapter. Depending on your model, your heater may include a fixed-setting thermostat or an adjustable thermostat.

**Corporate & Manufacturing
Headquarters**
5723 E. Alki Ave
Spokane, WA 99212 USA
509.536.8660
sales@hotstart.com

Oil & Gas Office
21732 Provincial Blvd.
Suite 170
Katy, TX 77450 USA
281.600.3700
oil.gas@hotstart.com

Europe Office
HOTSTART GmbH
Am Turm 86
53721 Siegburg, Germany
+49.2241.12734.0
europe@hotstart.com

Asia Pacific Office
HOTSTART Asia Pacific Ltd.
2-27-15-4F Honkomagome
Bunkyo-ku, Tokyo
113-0021, Japan
+81.3.6902.0551
apac@hotstart.com

INSTALLING THE IMMERSION HEATER

NOTICE

Overheating hazard: Do not install the immersion heater above the minimum fluid level. A heater element that is not completely submerged can cause overheating and damage the fluid.

Improper installation: HOTSTART recommends installing the immersion heater in the sides or bottom of a tank or sump. Installing the heater at the top of a tank or sump may cause a change in the fluid level to expose the element to air, causing overheating and damage to the heater and fluid.

1. Drain sump or tank.
2. Select tank or sump port based on your heater element length and thread size (threaded plug models) or element adapter size (threadless, V-clamp models).

NOTE: To prolong element life, avoid installation in locations where the heating element may come in contact with sludge or debris, typically at or near the bottom of a tank.

3. Install immersion heater:

➤ For threaded plug models:

1. Apply pipe compound to threads to protect threads from damage during installation.
2. Insert heater element and screw into port.

NOTE: HOTSTART recommends tightening the element assembly to port hand tight plus 1-1/2 to 2-1/2 additional turns as necessary to prevent leaks.

➤ For threadless, V-clamp models:

1. Center weldable adapter (D) on port. See Fig 2. Weld adapter in place.

NOTE: Port minimum diameter should be 2-1/2 inches (63 mm); maximum diameter should be 2-3/4 inches (69 mm).

NOTE: Protect surfaces from weld spatter. HOTSTART recommends stainless steel weld wire. Weld per local applicable welding code.

2. Slide O-ring (C) over element. Slide V-clamp (B) over element.
3. Insert element into port. Slide V-clamp (B) over weldable adapter (D) and element adapter (A). Ensure O-ring (C) is in place.
4. Tighten V-clamp screw to secure heater to port.

NOTE: To avoid leaks, HOTSTART recommends tightening the V-clamp screw to 25 lbf · in (282 N · cm).

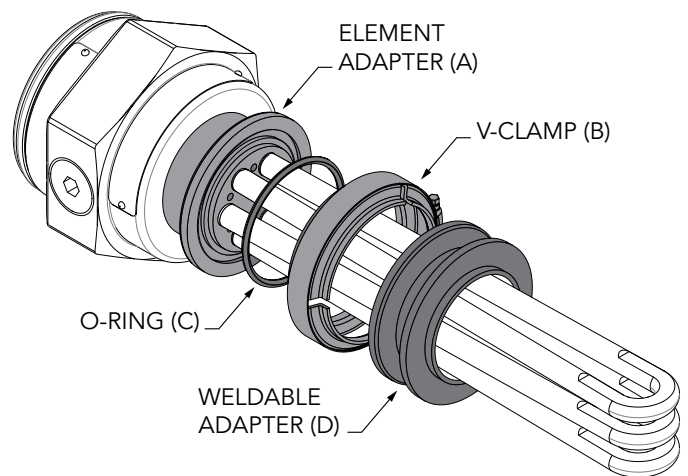

Figure 2. Industrial immersion V-clamp assembly components.

WIRING THE IMMERSION HEATER

CAUTION

Personal injury: Disconnect power supply before performing any electrical work. Wiring must be performed by a trained technician and in accordance with national and local electrical codes.

Electrical hazard: The heater must be connected to a suitable protective earthing conductor. The heater's power supply must be connected to a suitable overcurrent limiting device. A means of disconnection from power supply is required. HOTSTART recommends that a power switch or circuit breaker be located near the heater for safety and ease of use. Reference markings on heater for specific ratings.

NOTICE

Overheating hazard: Terminals in all enclosures require wire rated for a minimum of 105 °C. Selected wire must be sized in accordance with heater amperage.

Electrical enclosure: The electrical enclosure must remain covered to protect terminals from moisture and vapor. Ensure that proper covers are used for location conditions, such as weathertight locations or Class I, Group D hazardous locations.

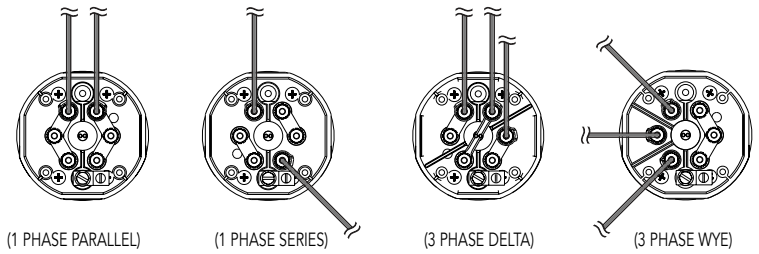

Figure 3. Weathertight industrial immersion wiring configurations.

WIRE THE ELEMENT

1. Remove element enclosure cover. Note your heater's element configuration.
2. Remove wiring enclosure opening:
 - For weathertight models, remove wiring enclosure knockout.
 - For Class I, Group D models for hazardous locations, unscrew plug from wiring entrance.
3. Connect appropriate conduit, cord connections, and cable connectors to wiring enclosure.
4. Connect power source conductors to element posts. Using supplied washers and nuts, tighten electrical connections.

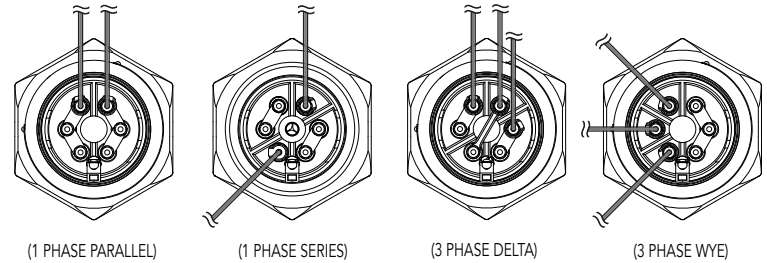

Figure 4. Class I, Group D hazardous location industrial immersion wiring configurations.

NOTE: HOTSTART recommends tightening electrical connections to 14 lbf · in (158 N · cm).

CONNECT WIRING COMPONENTS

1. Depending on your immersion heater's configuration, you may be required to install a control transformer or contactors.
 - If your immersion heater is **single-phase**, determine if your heater requires a contactor or contactor and transformer to complete installation (see Table 1).
 - If your thermostat's voltage rating and amperage limit are not exceeded, neither a contactor nor a transformer are required. (see Fig. 5). If your heater's voltage exceeds your thermostat's voltage rating (277 V for fixed or 480 V for adjustable), a control transformer and contactor will be required (see Fig. 6). If your heater's wattage exceeds your thermostat's amperage limit, a contactor will be required (see Fig. 7).

THERMOSTAT RATING			
THERMOSTAT	VOLTS	AMP LIMIT	CONTACTOR REQUIRED
Fixed	120 V	15 amps	> 1.8 kW
Fixed	208 V	10 amps	> 2.0 kW
Fixed	240 V	10 amps	> 2.4 kW
Fixed	277 V	7 amps	> 1.9 kW
Adjustable	120 V	30 amps	> 3.6 kW
Adjustable	240 V	30 amps	> 7.2 kW
Adjustable	277 V	30 amps	> 8.2 kW
Adjustable	480 V	20 amps	> 9.6 kW

Table 1. Thermostat amperage and voltage limits.

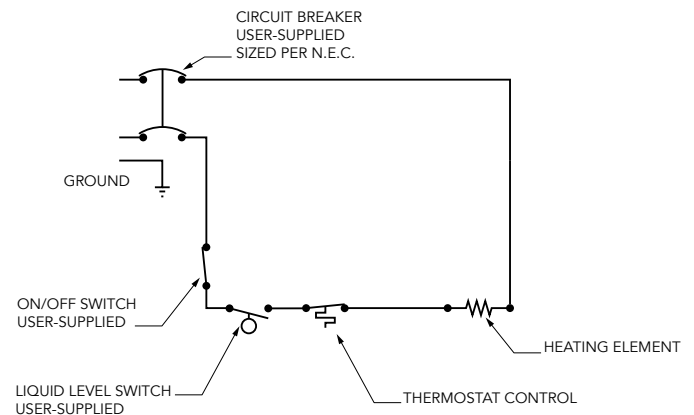

Figure 5. Wiring schematic without user-supplied contactor or control transformer. This schematic applies to single-phase heaters that do not exceed the thermostat's amperage and voltage limit.

➤ If your immersion heater is **three-phase and rated for over 240 volts**:

- A user-supplied control transformer and contactor are required to complete your heater's installation. See Fig 6.

➤ If your immersion heater is **three-phase and rated for 240 volts or less**:

- A user-supplied contactor is required to complete your heater's installation. See Fig 7.

2. Install a user-supplied liquid level switch at or above the level of the immersion heater. Wire the liquid level switch to ensure the heater will be de-energized in the event the liquid drops to or below the level of the element.

3. If your immersion heater is not equipped with an included high-limit thermostat, adjustable thermostat or resistance temperature device (RTD), a user-supplied temperature control must be installed.

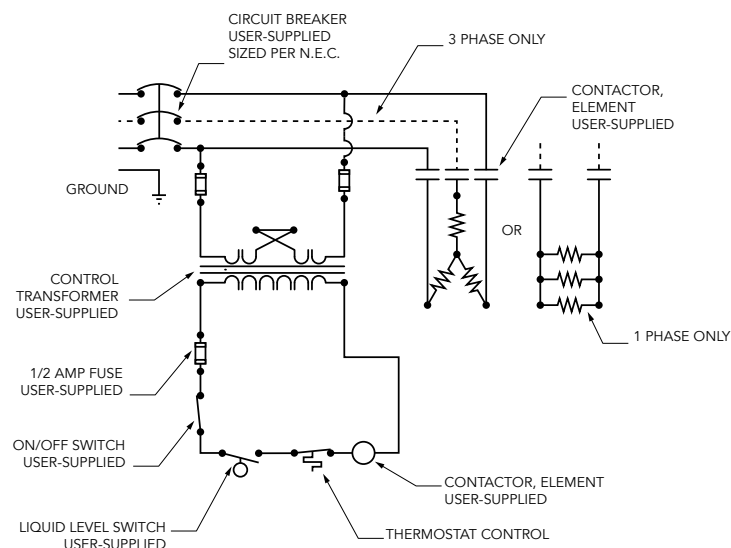

Figure 6. Wiring schematic showing element contactor and transformer with control circuit. This schematic applies to single-phase heaters that exceed thermostat voltage and amperage limits. This schematic also applies to three-phase heaters rated for over 240 volts.

MAINTENANCE

Every two years:

- Check electrical wiring and connections for wear and excessive heat.
- Remove element. Clean element and tank.

REPLACEMENT PARTS

Thermostat sensing units have a finite life. HOTSTART recommends that thermostat sensing units be replaced every 3 years or 25,000 hours of operation. For all replacement part details and specifications, call HOTSTART.

Industrial immersion heaters have the following replacement parts available (sold separately):

- Thermostat sensing unit
- Adjustable thermostat assembly

To remove and replace a thermostat sensing unit or adjustable thermostat, use the following steps:

1. Remove element enclosure cover.
2. For models with fixed thermostat, pull thermostat plug upwards to remove thermostat plug and thermostat sensing unit. Pull sensing unit from plug. See Fig. 8.
3. For models with adjustable thermostat, unscrew and remove complete adjustable thermostat assembly. See Fig. 8.

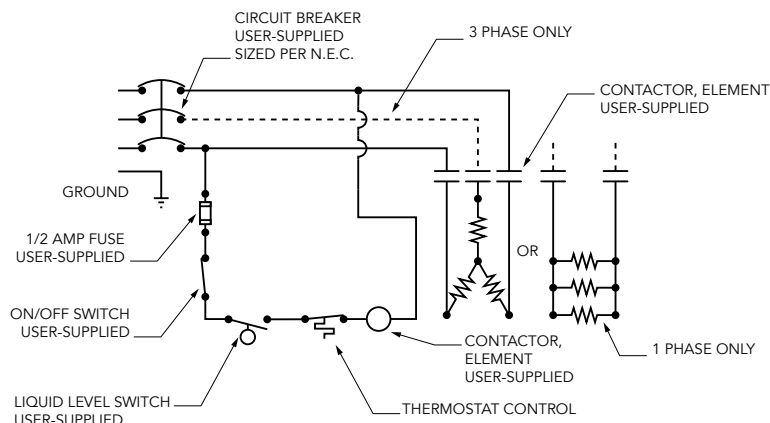

Figure 7. Wiring schematic showing element contactor with control circuit. This schematic applies to single-phase heaters that exceed thermostat amperage limits but fall within thermostat voltage limits. This schematic also applies to three-phase heaters rated for 240 volts or less.

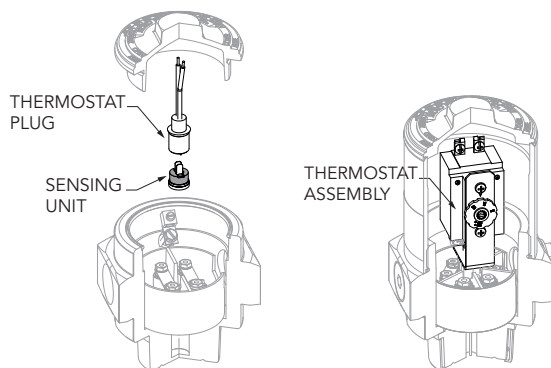

Figure 8. Replacing fixed thermostat sensing unit (left) and adjustable thermostat (right).