

INSTALLATION & OPERATION MANUAL

DUAL FLUID CIRCULATING HEATING SYSTEM
FOR HAZARDOUS LOCATIONS

MODEL

OCLE



(this page intentionally left blank)

IDENTIFYING YOUR SYSTEM

IOM216272-000

The HOTSTART heating system is designed to heat fluids for use in marine propulsion, diesel-powered generator sets, locomotives, gas compression or any large-engine applications. Each heating system has an identification plate which includes the part number and serial number.

This operation manual describes the installation, operation and maintenance of the heating system. Model specifics, capabilities and features may vary. See part drawings for dimensions and specifications.

When ordering replacement parts, be sure to reference your heating system's **MODEL NUMBER** and **SERIAL NUMBER** found on the identification plate and following label:



HOTSTART. 	SPOKANE, WA U.S.A.	REF. SERIAL NUMBER WHEN ORDERING REPLACEMENT PARTS
MODEL _____		
VOLTS _____ HERTZ _____		
AMPS. _____ PHASE _____		
CONTROL CIRCUIT VOLTS _____		
CONTROL CIRCUIT AMPS. _____ MAX		
SERIAL NUMBER _____		
	CAUTION	U.S. PATENTS 4,245,593, 4,249,491 CAN. PATENTS 1,067,473, 1,062,541
OPEN CIRCUITS BEFORE WORKING ON THIS EQUIPMENT OR REMOVING COVERS. KEEP COVERS TIGHTLY CLOSED WHILE CIRCUITS ARE ALIVE.		

NOTE: Typical heating system identification plate. Your identification plate may vary.

WARRANTY INFORMATION

Warranty information can be found at www.hotstart.com or by contacting our customer service department at **(509)536-8660**. Have your **MODEL NUMBER** and **SERIAL NUMBER** ready when contacting the warranty department.

COPYRIGHT

Hotstart Manufacturing, Inc. is the owner of all trademarks and copyrightable material contained herein; all rights are reserved; no form of reproduction is authorized without prior written consent from Hotstart Manufacturing, Inc.

Corporate & Manufacturing Headquarters
5723 E. Alki Ave.
Spokane, WA 99212 USA
509.536.8660
sales@hotstart.com

Oil & Gas Office
21732 Provincial Blvd.
Suite 170
Katy, TX 77450 USA
281.600.3700
oil.gas@hotstart.com

Railroad Office
8915 Broadway
Merrillville, IN 46410 USA
219.648.2448
railroad@hotstart.com

Europe Office
HOTSTART Europe GmbH
Hansestraße 79
51149 Köln, Germany
+49.2203.98137.30
europe@hotstart.com

Asia Pacific Office
HOTSTART Asia Pacific Ltd.
2-27-15-4F Honkomagome
Bunkyo-ku, Tokyo
113-0021, Japan
+81.3.6902.0551
apac@hotstart.com

IMPORTANT SAFETY INFORMATION

DANGER

Hazardous voltage: Before wiring, servicing or cleaning the heating system, turn off the power and follow your organization's lockout and tagout procedure. Failure to do so could allow others to turn on the power unexpectedly, resulting in harmful or fatal electrical shock.

Combustion hazard: To prevent ignition of flammable or combustible atmospheres, disconnect power before servicing.

WARNING

Risk of ignition: To reduce the risk of ignition in hazardous atmospheres, disconnect the equipment from the supply circuit before opening system enclosures. Keep enclosures tightly closed when in operation.

Sealing fittings: To reduce the risk of ignition in hazardous atmospheres, conduit runs must have a sealing fitting connected within 18 inches (46 cm) of system enclosure.

WARNING



Electrical hazard: All electrical work must be done by qualified personnel in accordance with national, state and local codes.

CAUTION

Read instructions carefully: The safety of any system incorporating this equipment is the responsibility of the assembler. The safe and proper use of this equipment is dependent upon the installer following sound engineering practices. If the equipment is used in a manner not specified by the manufacturer, the protection provided by the equipment may be impaired. All applicable electrical safety standards defined by local jurisdictions must be followed. (Reference EU directive 2014/34/EU in EU countries.)

- **Read carefully:** Installers and operators of this equipment must be thoroughly familiar with the instructions in this manual before commencing work.
- **Hot surfaces:** Avoid contact with the system while it is in service. Some surfaces may remain hot even if the system is not energized.
- **Proper lifting:** Use proper lifting equipment and rigging to move this equipment. Create a plan before attempting to move. Proper lifting locations are identified with labels on each system; use these locations when lifting and mounting the system.

- **Rotating equipment:** The heating system can start automatically and without warning. Avoid contact unless a lockout at the service panel has been installed.
- **Grounding:** The heating system must be connected to a suitable ground (protective earthing conductor).
- **Overcurrent limiting:** The power supply must be protected by a suitable overcurrent limiting device.
- **Power disconnection:** A means to disconnect the heating system from the power supply is required. HOTSTART recommends that a power switch or circuit breaker be located near the heating system for safety and ease of use. **Suitable branch circuit protection shall be installed in accordance with Article 430 Part IV of the NEC.**
- **Flameproof joints:** Flameproof joints are not intended to be repaired in the field. Do not attempt to repair any flameproof joints that become damaged.
- **Bend radius:** Do not adjust cable bend radius in the field. Cables are pre-wired to meet the minimum requirements for bend radius. If a cable is moved from factory positioning, adjust cable to ensure minimum bend radius met. For MC-HL cable, minimum bend radius is $7 \times (\varnothing)$ outer diameter of the cable. For TC-ER-HL cable, minimum bend radius is $4 \times (\varnothing)$ outer diameter

CERTIFICATIONS

Certifications:

- Class I Div 1 Group D T3A
- Class I Zone 1 Group IIA T3

Some models:

- Class I Div 2 Group D T3A
- Class I Zone 2 Group IIA T3

Max/ Min. process fluid temp.	0 °C to 80 °C
Ambient temp.	-20 °C to 40 °C
Voltages	120 to 575 V AC, 50/60 Hz, 1/3 phase

TABLE OF CONTENTS

1	OVERVIEW 1	4	MAINTENANCE AND TROUBLESHOOTING 12
1.1	HEATING SYSTEM COMPONENTS 1	4.1	SYSTEM FAULTS 12
1.2	OPERATION OVERVIEW 2	4.1.1	Coolant Faults 12
2	INSTALLATION 3	4.1.2	Oil Faults 12
2.1	OIL PLUMBING INSTALLATION 4	4.2	SYSTEM MAINTENANCE 13
2.1.1	Oil Supply 4	4.2.1	Plumbing Connections 13
2.1.2	Oil Return 4	4.2.2	Electrical Connections 13
2.2	OIL PLUMBING ILLUSTRATION 5	4.2.3	System Mounting 13
2.3	COOLANT PLUMBING INSTALLATION 6	4.2.4	Magnetic Contactors 13
2.3.1	Coolant Supply 6	4.2.5	Pump Seal 13
2.3.2	Coolant Return 6	4.2.6	Pressure Relief Valve 13
2.3.3	Coolant Pressure Relief 6	4.2.7	Pressure/ Temperature Gauge 13
2.4	COOLANT PLUMBING ILLUSTRATION 7	4.2.8	Volatile Corrosion Inhibitor 13
2.5	MOUNTING 8	4.2.9	Temperature Control Relay 14
2.5.1	Tank and Pump 8	4.3	RECOMMENDED MAINTENANCE 15
2.6	ELECTRICAL CONNECTIONS 8	4.4	STORAGE REQUIREMENTS 15
2.6.1	Main Power Supply 8	4.5	TROUBLESHOOTING 16
2.6.2	Customer Interface Connections 9		
2.6.3	Motor Rotation Check 10		
3	COMPONENTS AND OPERATION 10		
3.1	SYSTEM COMPONENTS 10		
3.1.1	Motor Protection Switch 10		
3.1.2	Control TCR (Temperature Control Relay) 10		
3.1.3	High-Limit TCR (Temperature Control Relay) 10		
3.2	INTERFACE COMPONENTS 10		
3.2.1	Local/Off/Remote Switch 10		
3.2.2	Prime Button 10		
3.2.3	Reset Button 10		
3.2.4	Pressure/Temperature Gauge 11		
3.2.5	Oil Pressure Relief Valve 11		
3.2.6	Coolant Pressure Relief Valve 11		
3.3	HEATING SYSTEM START-UP 12		
3.3.1	First Run Procedure 12		

(this page intentionally left blank)

1 OVERVIEW

⚠ WARNING

System location classification: Before installing the OCLE heating system, ensure all system components are suitable for the intended installation location by referring to the location classification labeling attached to the individual system components.

1.1 HEATING SYSTEM COMPONENTS

NOTE: Component illustrations are for reference only and are not to scale. See part drawings for dimensions and specifications.

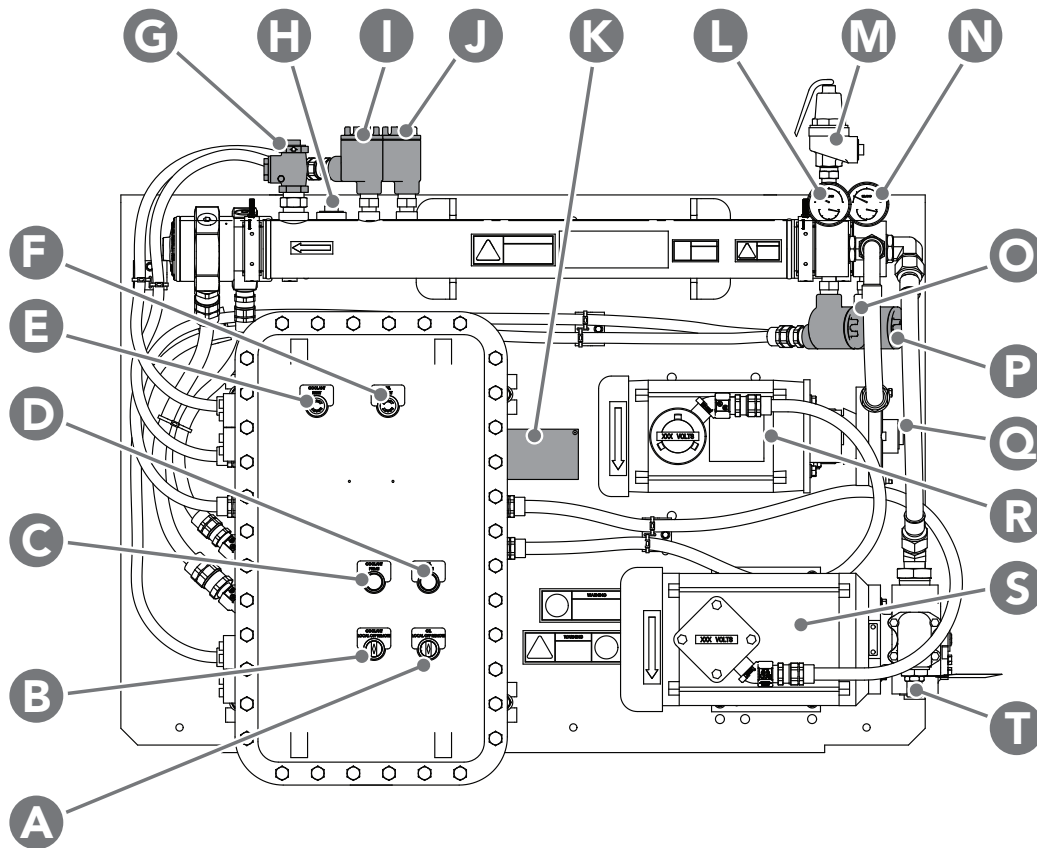

- | | | |
|------------------------------------|---|--|
| A. Oil LOCAL/OFF/REMOTE switch | I. Coolant high-limit resistance temperature device (RTD) | O. Coolant control resistance temperature device (RTD) |
| B. Coolant LOCAL/OFF/REMOTE switch | J. Oil high-limit resistance temperature device (RTD) | P. Oil control resistance temperature device (RTD) |
| C. Coolant PRIME button | K. Identification plate | Q. Coolant inlet (1.25" NPT) |
| D. Oil PRIME button | L. Coolant pressure/temperature gauge | R. Coolant pump/motor |
| E. Coolant RESET button | M. Pressure relief valve (0.75" NPT) | S. Oil pump/motor |
| F. Oil RESET button | N. Oil pressure/temperature gauge | T. Oil inlet (0.5"1.0"1.5" NPT see part drawings) |
| G. Coolant outlet (1" NPT) | | |
| H. Oil outlet (1" NPT) | | |

Figure 1. Typical OCLE system components. Model style and configuration may vary. See part drawings for dimensions and specifications.

1.2 OPERATION OVERVIEW

The OCLE heating system is intended to maintain both optimal engine and oil temperature as well as prevent condensation while the engine is shut down. The heating system may be activated locally or by optional remote control (see **SECTION 2.6.2**). The OCLE heating system must be deactivated upon engine start-up.

During heating system operation, a centrifugal pump takes coolant from the drain area low on the engine water jacket and forces it through the heating tank and into the coolant return line. Simultaneously, a positive displacement pump takes oil from the sump and forces it through the heating tank to the oil return line. The coolant pump and oil pump will continuously circulate fluid throughout the engine. To maintain consistent fluid temperature, the heating elements will cycle on and off at the user-selected temperature control point.

A coolant check valve (included with the OCLE unit and installed at the coolant outlet) and an oil check valve (user-supplied and installed near the oil suction port) prevent backflow while the engine is operating. When the engine is shut down, the heating system should be activated locally or remotely to resume maintaining the engine's optimal starting temperature.

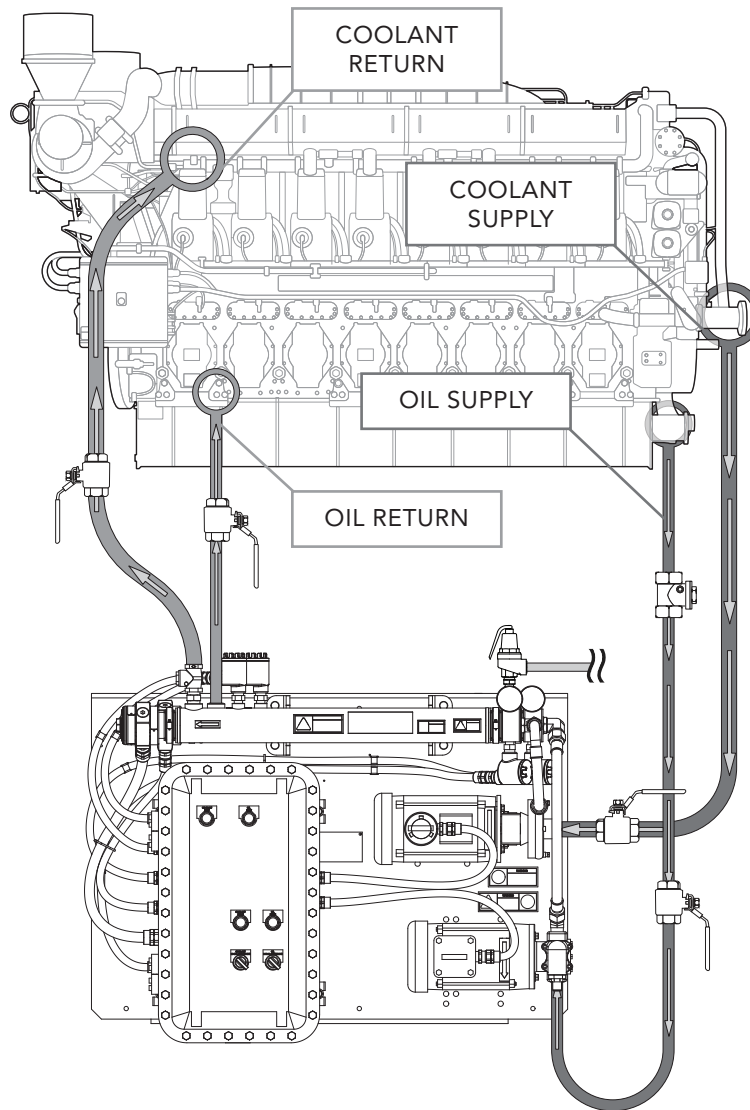

Figure 2. OCLE system operation. Component illustrations are for reference only and are not to scale. See part drawings for dimensions and specifications.

2 INSTALLATION

CAUTION

Pressure hazard: Power must be turned off and locked out at the service panel when the isolation valves are in the closed position. Failure to do so may cause damage to heating system components, leaks, damage to lubrication oil and unexpected release of heated coolant or heated oil.

Pressurized steam hazard: Coolant pressure relief valve outlet must be plumbed to a safe area in case an over-pressure release of heated coolant occurs. Do not connect pressure relief plumbing to heating system or engine coolant system. See **SECTION 2.3.3**.

Overheating hazard: After completing line installation, top off the fluid levels to compensate for the fluid used to fill the lines and heating tank. Do not operate the heating system without the presence of fluid. Position the heating tank to ensure it is completely full of fluid while in operation.

Pump priming: Fill supply line with fluid. Pump is not self-priming. Fluid must be present in the pump before start-up. Trapped air inside the pump will cause pump and seal damage.

Pump seal damage: Do not reduce the fluid supply lines to an inner diameter smaller than the pump inlet; pump seal damage could occur.

Check valve: HOTSTART recommends installing a customer-supplied swing-type or full-flow check (non-return) valve to prevent oil from flowing back into the oil sump. If the pump is installed above the minimum oil level, a check valve **must** be installed.

Isolation valves: HOTSTART recommends installing full-flow ball valves to isolate the heating system in order to perform service on the system or engine without draining the fluid.

2.1 OIL PLUMBING INSTALLATION

NOTICE

Heating system damage: Engine vibration will damage the heating system; isolate the heating system from vibration. Never mount the heating system or components directly to the engine. If the heating system is installed using rigid pipe, use a section of flexible hose to the supply and return ports to isolate the heating system from engine vibration.

2.1.1 OIL SUPPLY

Installing a short, straight oil supply line with a minimum of flow restriction is the most important step toward ensuring heating system longevity. When installing the OCLE oil supply line, refer to the following HOTSTART guidelines:

- Due to the increased viscosity of lubrication oil, the oil supply line must be as short and as straight as possible. Any 90° elbows will reduce the maximum recommended oil supply length. See Table 1 for HOTSTART OCLE oil supply recommendations:

PUMP INLET	HOSE INNER DIAMETER	MAX. LINE LENGTH	MAX. ELBOW COUNT
1/2 inch NPT	1 inch	20 feet (6 meters)	4
1 inch NPT	1-1/2 inch	20 feet (6 meters)	4
1-1/2 inch NPT	2 inch	20 feet (6 meters)	4

Table 1. HOTSTART recommended hose inner diameters, line lengths and elbow counts for OCLE oil supply lines.

NOTE: Each additional pair of 90° elbows will reduce the maximum recommended line length by five feet (1.5 meters). To minimize flow restriction, HOTSTART recommends using sweeping bends or 45° fittings.

- At a minimum, size the oil supply line per the pump inlet. **NOTICE!** Do not reduce the supply line inner diameter; pump seal damage will occur.

NOTE: To maximize flow and allow the longest possible supply line, install the largest practical inner diameter hose; for most installations, HOTSTART recommends using a hose with a size larger inner diameter than the pump inlet.

- Install the oil suction port as low as possible in the oil sump. **NOTICE!** Avoid installing the oil suction port in a location that may allow debris or sediment to enter the heating system.
- HOTSTART recommends installing a customer-supplied, swing-type or full-flow check (non-return) valve to prevent oil flowing into the sump. Install the check valve as close to the oil supply port as possible.
- To ensure consistent oil heating, it is acceptable to select a suction port on the opposite side of the sump.

2.1.2 OIL RETURN

When installing the OCLE oil return line, refer to the following HOTSTART guidelines:

- At a minimum, size the oil return line per the pump outlet. **NOTICE!** Do not reduce the return line inner diameter.
- The oil return line **must** be routed to the oil discharge port located at the end of the oil sump opposite the suction port. See **SECTION 2.2**.

2.2 OIL PLUMBING ILLUSTRATION

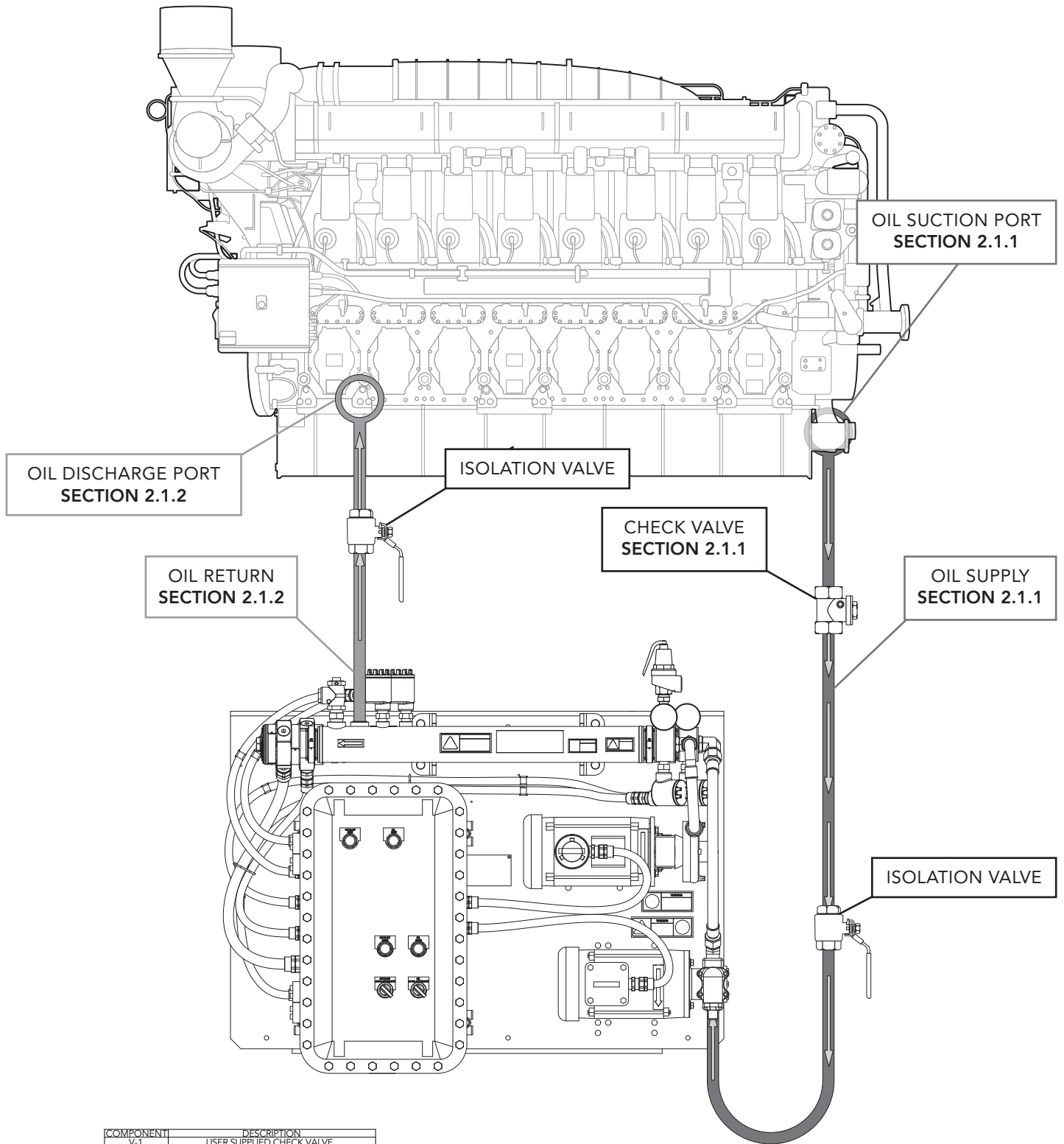

OIL SUCTION PORT
SECTION 2.1.1

OIL DISCHARGE PORT
SECTION 2.1.2

ISOLATION VALVE

CHECK VALVE
SECTION 2.1.1

OIL RETURN
SECTION 2.1.2

OIL SUPPLY
SECTION 2.1.1

ISOLATION VALVE

COMPONENT	DESCRIPTION
V-1	USER SUPPLIED CHECK VALVE
V-2	USER SUPPLIED FULL FLOW ISOLATION VALVE
E-1	OIL PUMP
E-2	OIL HEATING ELEMENT
V-3	USER SUPPLIED FULL FLOW ISOLATION VALVE

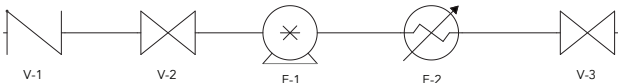

2.3 COOLANT PLUMBING INSTALLATION

NOTICE

Heating system damage: Engine vibration will damage the heating system; isolate the heating system from vibration. Never mount the heating system or components directly to the engine. If the heating system is installed using rigid pipe, use a section of flexible hose to the supply and return ports to isolate the heating system from engine vibration.

2.3.1 COOLANT SUPPLY

When installing the OCLE coolant supply line, refer to the following HOTSTART guidelines (See **SECTION 2.4**):

- At a minimum, size the coolant supply line per the pump inlet. **NOTICE!** Do not reduce the supply line inner diameter; pump seal damage will occur.
 - NOTE:** To maximize flow and allow the longest possible supply line, install the largest practical inner diameter hose; for most installations, HOTSTART recommends using a hose with a size larger inner diameter than the pump inlet.
- Install the coolant suction port as low as possible on the engine's water jacket. Where applicable, HOTSTART recommends a connection point at the suction side of the engine water pump **(A)**. **NOTICE!** At a minimum, suction port must be sized per the pump inlet (1.25" NPT).
- To minimize flow restriction, the coolant supply line must be as short and as straight as possible. Use elbow fittings sparingly; HOTSTART recommends using sweeping bends or 45° fittings.
 - NOTE:** For optimal pump performance, HOTSTART recommends a minimum of 6 inches (152 mm) of straight pipe installed into pump inlet.

2.3.2 COOLANT RETURN

When installing the OCLE coolant return line, refer to the following HOTSTART guidelines(See **SECTION 2.4**):

- Size the coolant return line per the coolant outlet. **NOTICE!** Do not reduce the return line inner diameter.
- Install the coolant discharge port as high as possible on the engine's water jacket at the end of the engine opposite the suction port, typically at the rear of the engine block on the engine water rails **(B)**.

2.3.3 COOLANT PRESSURE RELIEF

- To safeguard personnel and equipment, attach an appropriately-sized pipe to the pressure relief valve and route to a safe area, bucket or catch-basin. **CAUTION!** Coolant pressure relief valve outlet must be plumbed to a safe area in case an over-pressure release of heated coolant occurs. Do not connect pressure relief plumbing to heating system or engine coolant system.

2.4 COOLANT PLUMBING ILLUSTRATION

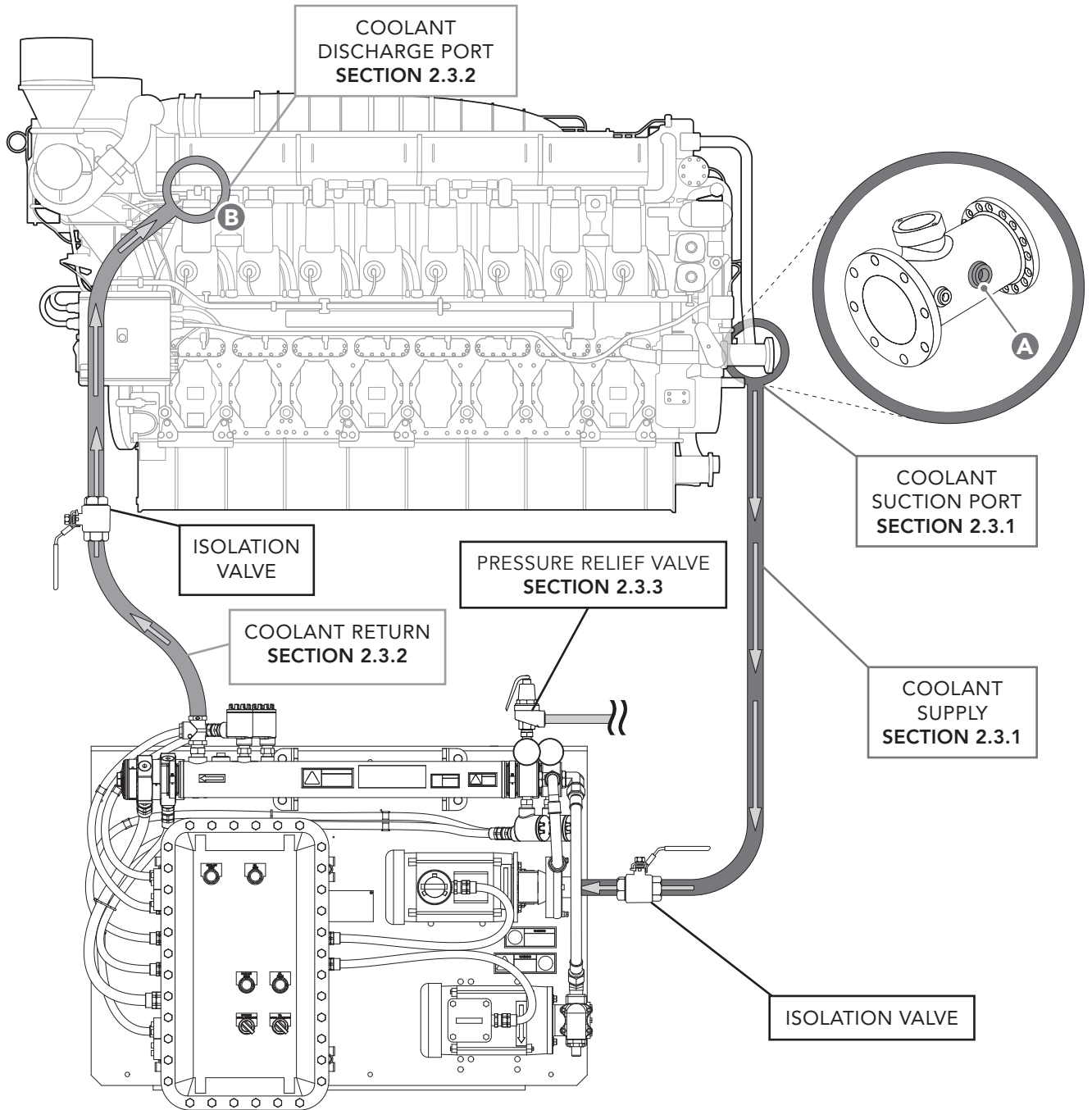

COMPONENT	DESCRIPTION
V-1	USER SUPPLIED FULL FLOW ISOLATION VALVE
E-1	COOLANT PUMP
E-2	COOLANT HEATING ELEMENT
V-2	PRESSURE RELIEF VALVE
V-3	USER SUPPLIED FULL FLOW ISOLATION VALVE

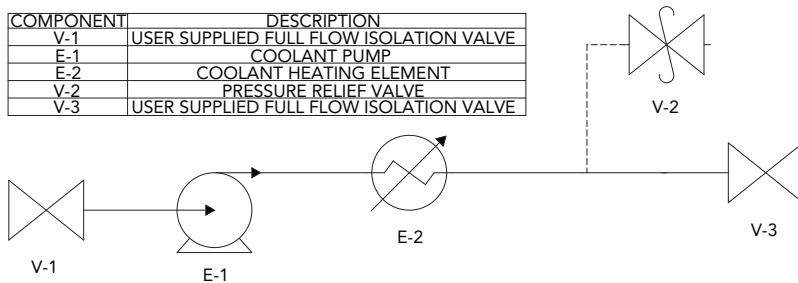

2.5 MOUNTING

CAUTION

Lifting hazard: Proper rigging and safety equipment must be used to move this equipment. Do not lift the heating system by any cords, electrical conduit or cabling. Create a plan before attempting to move. Proper lifting locations are identified on each system; use these locations when lifting and mounting the system.

Overheating hazard: When mounting the heating tank, position the tank so that it is completely full of fluid while in operation.

NOTICE

Heating system damage: Engine vibration will damage the heating system; isolate the heating system from vibration. Never mount the heating system or components directly to the engine.

Improper mounting hazard: Reference heating system component drawings before mounting the system. Unless mounted properly, the heating system will be unstable.

2.5.1 TANK AND PUMP

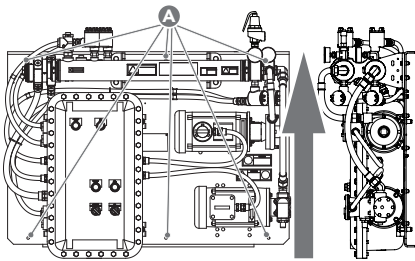

Figure 3. OCLE 0.438 inch (11.13 mm) diameter mounting holes × 6 (A). Mount unit in orientation shown. Do not mount at an angle or in any other orientation.

Mount the heater in a vertical orientation with tank directly above control box and pump. Reference drawings for mounting position. When installing the heating system, note that the tank requires a minimum of 30 inches (63.5 cm) of clearance to remove element for maintenance.

2.6 ELECTRICAL CONNECTIONS

WARNING



Hazardous voltage: Before wiring, servicing or cleaning the heating system, turn off the power and follow your organization's lockout and tagout procedure. Failure to do so could allow others to turn on the power unexpectedly, resulting in harmful or fatal electrical shock. Install in accordance with the National Electrical Code (NEC) or Canadian Electrical

Code (CEC), and any applicable local codes (such as NFPA 496), based on the installation location.

Electrical hazard: The heating system must be connected to a suitable protective earthing conductor. The heating system's power supply must be connected to a suitable overcurrent limiting device. A means of disconnection from power supply is required. HOTSTART recommends that a power switch or circuit breaker be located near the heating system for safety and ease of use. Reference markings on heating system for specific ratings.

Grounding conductor: Equipment grounding conductors shall be sized per NEC 2017 Table 250.122 for US installations. For international installations, use IEC 60079-0, Clause 16. Ground terminal block will accept 16–4 AWG conductors. External grounding connection not provided. Metallic conduit or armored cable must be used.

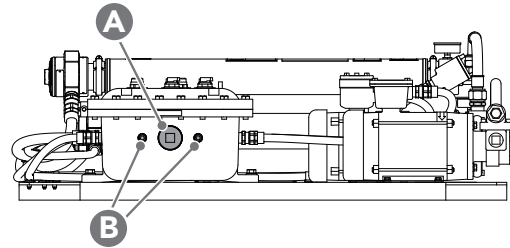

Figure 4. OCLE underside, showing 2" NPT main power entrance (A) and 0.5" NPT customer interface wiring entrance (B).

2.6.1 MAIN POWER SUPPLY

1. Connect the specified power from the customer-supplied circuit breaker to the terminal blocks located in the main control box. See Fig. 5 on following page.

NOTE: Connect the specified power from the customer-supplied circuit breaker to the terminal blocks located in the main control box. See Fig. 4 and Table 2.

NOTE: The specified power source must be within plus or minus 10% of the rated voltage.

Wire Size	Torque	Copper Wire Stranding Classes – Number of Strands						
		Solid	Class B	Class C	Class G	Class H	Class I	Class K
2/0 AWG	120 in·lbs		19	37				
1/0	120 in·lbs		19	37				
1	120 in·lbs		19	37	~133	~259	~210	~836
2	120 in·lbs		7	19	~49	~133	~161	~665
4	120 in·lbs		7	19	~49	~133	~105	~420
6	120 in·lbs		7	19	~49	~133	~63	~266
8	40 in·lbs		7	19	~49	~133	~41	~168
10	35 in·lbs	1	7	19			~27	~104
12	35 in·lbs	1	7	19			~19	~65
14	35 in·lbs	1	7	19			~19	~41

Table 2. Line Side Wire Approvals. ~Quantity of strands for Classes G, H, I, K may vary by manufacturer. Aluminum stranded wire range: 2/0 – #6 AWG. Minimum 90 °C wire for all electrical connections.

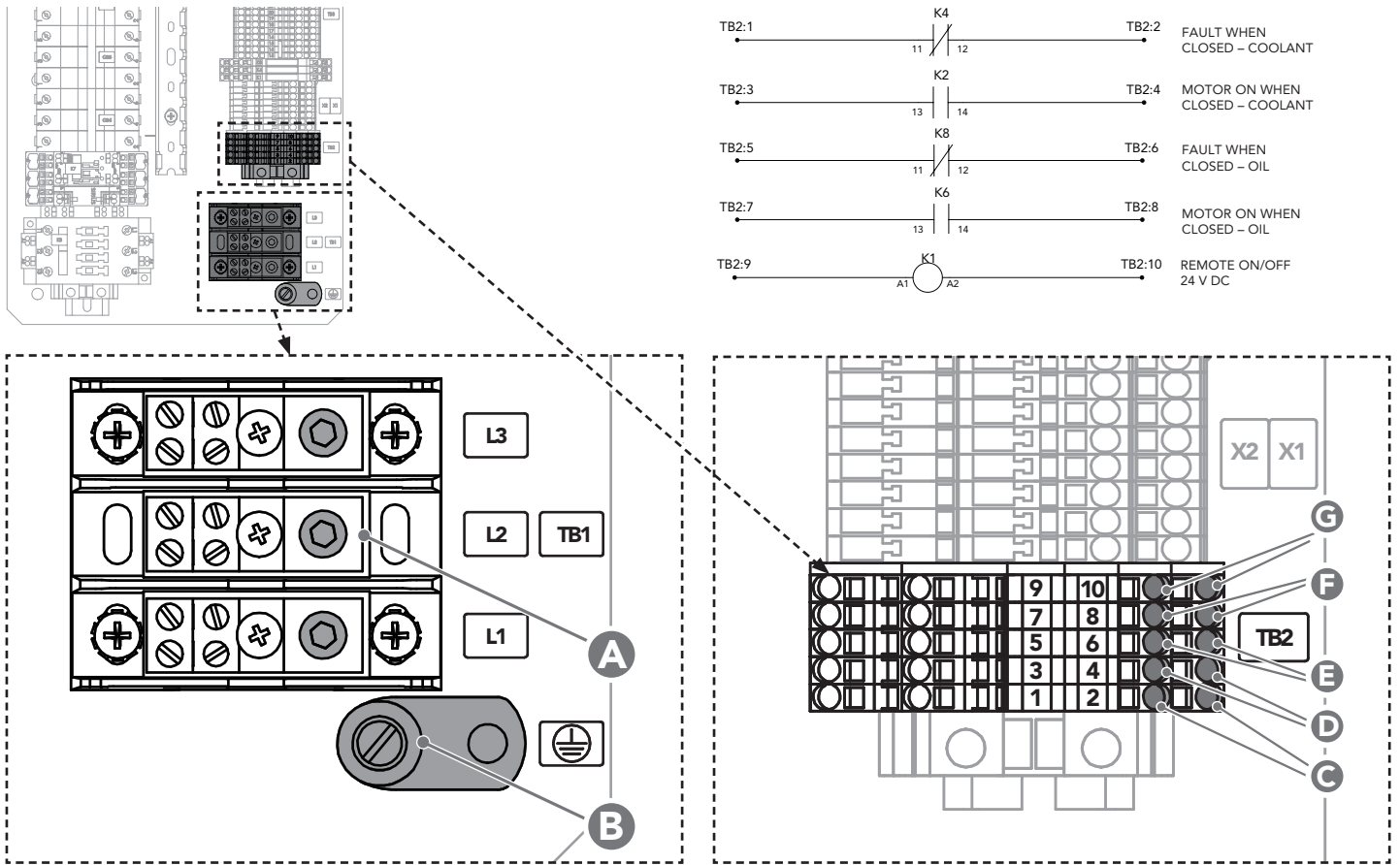

- A. Main power terminal block
- B. Main power ground block
- C. Coolant fault signal
- D. Coolant motor run signal
- E. Oil fault signal
- F. Oil motor run signal
- G. Remote On/Off 24 V DC shutdown

Figure 5. Main power supply and customer interface connections as shown in the OCLE control box. Reference electrical schematic drawing for proper wiring locations; the following illustrations are typical customer interface locations.

NOTE: The circuit breaker must be near the heating system and easily accessible. Suitable branch circuit protection shall be installed in accordance with Article 430 Part IV of the NEC. Minimum branch circuit size is detailed on your main system label, please verify amperage rating and SCCR ratings of your circuit breaker prior to installation.

NOTE: The main power supply operates the heating elements and the circulating pumps. A transformer is used to operate the control circuit. The transformer and control circuits are overload-protected.

NOTE: For **three-phase applications**, the terminal blocks are labeled **L1**, **L2** and **L3** (**A**).

➤ For **single-phase applications**, use the terminal blocks labeled **L1** and **L2** or **L** and **N** (**A**).

2. Connect the main power ground wire to the ground block (**B**).

2.6.2 CUSTOMER INTERFACE CONNECTIONS

The following customer interface connections are available for remote control and monitoring:

- **Remote On/Off 24 V DC shutdown (G) TB2:9/TB2:10**

When activated, the remote on/off connection shuts down the heating system. When deactivated, normal heating will resume. Use this connection for remote operation of the heater when the LOCAL/OFF/REMOTE switch is turned to REMOTE.

NOTE: The **24 V DC shutdown** connection is wired **NC (normally closed)** from the factory; see system wiring schematic for directions to switch to **NO (normally open)** operation.

- **Fault Signal**
TB2:1/TB2:2 coolant (C)
TB2:5/TB2:6 oil (E)
 The fault signal will indicate a heating system shutdown, triggered by either the high-limit temperature control relay or the motor protection switch (see **SECTION 4.1**).
- **Motor Run Signal**
TB2:3/TB2:4 coolant (D)
TB2:7/TB2:8 oil (F)
 A motor run signal indicates the pump motor is running. If no signal is present, the pump motor is not running.

2.6.3 MOTOR ROTATION CHECK

NOTICE

Pump rotation (three-phase only): For three-phase applications, check for proper pump rotation prior to introducing fluid to the pump. Reverse rotation while the pump is filled with fluid will cause pump seal failure.

Pump damage: Do not run the motor/pump assembly dry for more than a few seconds. Running a motor/pump for a prolonged period without being completely filled with fluid may cause damage to the pump seal.

The following procedures are for three-phase applications only. Single-phase systems are prewired to ensure the pump motor rotates in the correct direction.

1. With main power connected to the heating system motor (see **SECTION 2.6.1**), energize the pump while observing the rotation of the pump motor fan at the rear of the motor. Refer to rotation decal on motor for correct rotation.
 - If the pump motor does not rotate in the correct direction, disconnect power and switch any two electrical leads at the main power terminal block (**L1, L2, L3**). Reconnect power. Repeat step 1 to ensure motor rotates in the correct direction.

3 COMPONENTS AND OPERATION

The following is an operational description for each of the OCLE interface and system components.

NOTE: Components installed in control box may vary depending on the particular system configuration purchased.

3.1 SYSTEM COMPONENTS

3.1.1 MOTOR PROTECTION SWITCH

The motor protection switch (MPS) protects the pump motor from overloads. The MPS will be set at the full load

amperage of the motor when shipped from the factory. To reset the MPS, the **LOCAL/OFF/REMOTE** switch must be switched to **OFF** and the operator must press the **RESET** button or press the MPS reset/on button (**B**). See *Fig. 7*. For additional troubleshooting, see **SECTION 4.5**.

3.1.2 CONTROL TCR (TEMPERATURE CONTROL RELAY)

The control TCRs (TCR1 and TCR3) are used to control the temperature of the corresponding fluid. The control TCR uses a resistance temperature device (RTD) to sense the temperature of the fluid as it enters the heater. The standard setting for the coolant control temperature relay (TCR1) is 122 °F (50 °C). The standard setting for the oil control temperature relay (TCR3) is 104 °F (40 °C). See *Fig. 7*.

3.1.3 HIGH-LIMIT TCR (TEMPERATURE CONTROL RELAY)

The high-limit TCRs (TCR2 and TCR4) are a protection device to prevent fluid overheating. The high-limit TCR uses a resistance temperature device (RTD) located near the tank outlet. The default setting for the coolant and oil high-limit TCR is 194 °F (90 °C) and should always be at least 18 °F (10 °C) higher than the corresponding control TCR set point. The high-limit TCR hysteresis is not used in the high-limit control. See *Fig. 7*.

3.2 INTERFACE COMPONENTS

3.2.1 LOCAL/OFF/REMOTE SWITCH

- LOCAL – The system is on.
- OFF – The system is shut off.
- REMOTE – The system will turn on and shut off on a signal from the 24 V DC remote connection. See **SECTION 2.6.2**.

3.2.2 PRIME BUTTON

Press and hold the **PRIME** button to energize the pump motor in order to remove any air in the heating system without energizing the elements. **NOTICE!** Do not run the motor/pump assembly dry for more than five seconds at a time.

NOTE: The **PRIME** function is intended for use during the first run procedure (see **SECTION 3.3.1**) or after performing maintenance on the heating system or plumbing (see **SECTION 4.3**).

3.2.3 RESET BUTTON

Press the **RESET** button to reset the pump motor protection switch without opening the control box. The reset function is intended for use immediately following resolving and repairing a system fault (see **SECTION 4.1**).

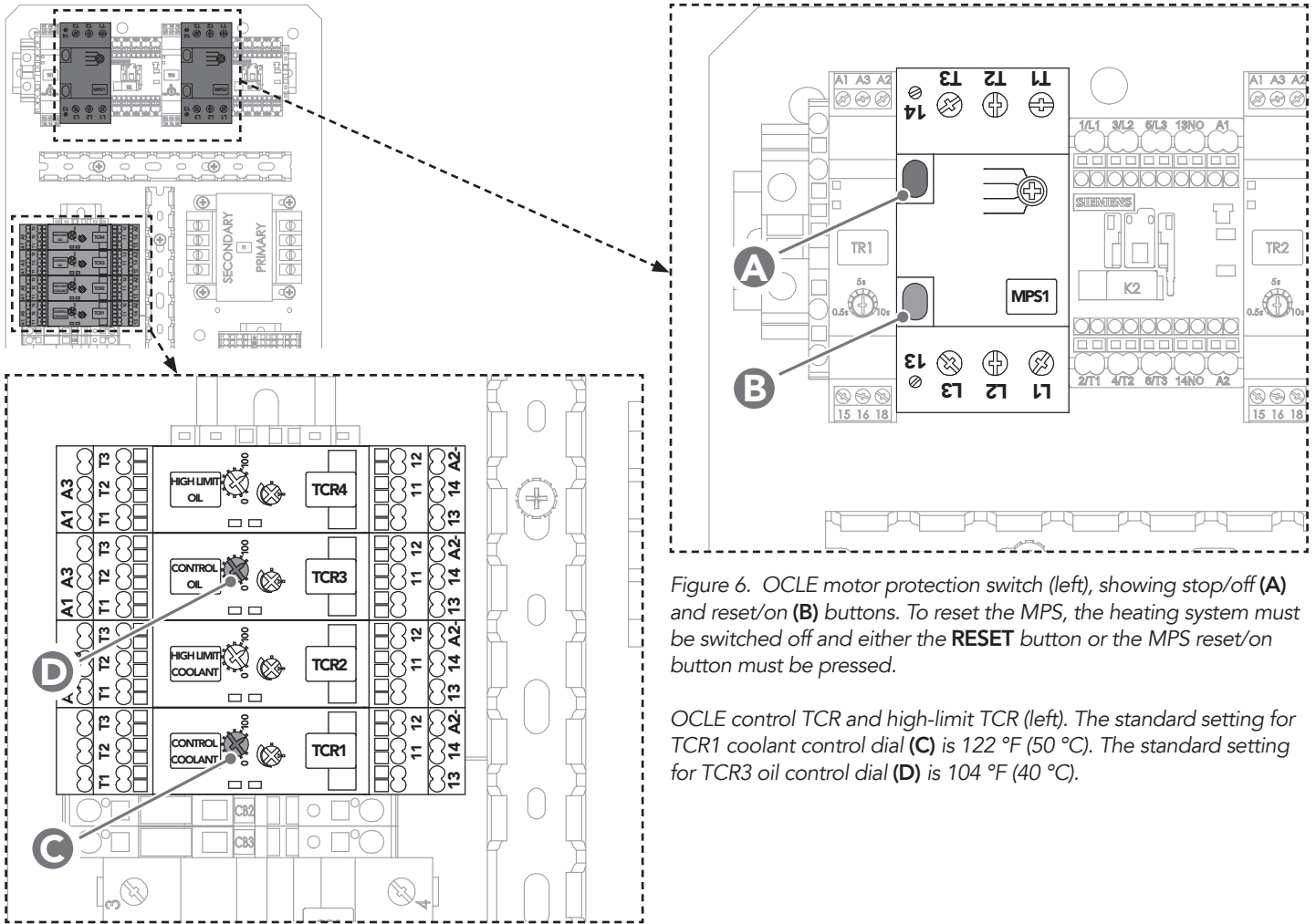

Figure 6. OCLE motor protection switch (left), showing stop/off (A) and reset/on (B) buttons. To reset the MPS, the heating system must be switched off and either the **RESET** button or the MPS reset/on button must be pressed.

OCLE control TCR and high-limit TCR (left). The standard setting for TCR1 coolant control dial (C) is 122 °F (50 °C). The standard setting for TCR3 oil control dial (D) is 104 °F (40 °C).

3.2.4 PRESSURE/TEMPERATURE GAUGE

The OCLE model features a temperature/pressure gauge mounted at the heating tank inlet. The gauge will indicate a pressure increase when the pump motor is engaged by pressing and holding the **PRIME** button or during normal operation. The gauge will also indicate the fluid's current temperature.

NOTE: Your system's operating pressure may vary depending on the configuration of the engine.

3.2.5 OIL PRESSURE RELIEF VALVE

The oil pump pressure relief valve is internal to the pump and releases pressure from the discharge side of the pump to the suction side of the pump at 75 psi (525 kPa). No plumbing for this component is required. The pressure relief valve cap must always point toward the inlet side of the pump.

The OCLE heating system is designed to not exceed 125 psi (862 kPa); however, the oil pump will not exceed 75 psi (517 kPa). In the event the pressure relief valve is

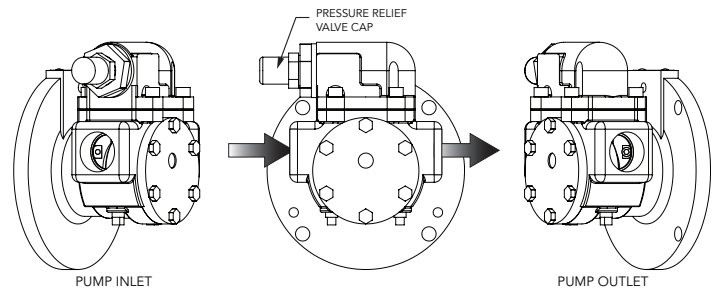

Figure 7. Typical OCLE pump assembly. Note that the pressure relief valve cap must always point toward the inlet side of pump.

activated, the pump will continue to produce flow, but will not exceed a pressure of 75 psi (517 kPa).

3.2.6 COOLANT PRESSURE RELIEF VALVE

CAUTION

Pressurized steam hazard: Coolant pressure relief valve outlet must be plumbed to a safe area in case an over-pressure release of heated coolant occurs.

The coolant pressure relief valve is mounted at the coolant heating tank outlet and is set to relieve at 100 psi (690 kPa). During normal operation, pressure release events are rare. To safeguard personnel and equipment, attach an appropriately sized pipe to the pressure relief valve outlet and direct flow to a safe area, bucket or other catch-basin. See **SECTION 2.3.3**.

3.3 HEATING SYSTEM START-UP



Hazardous voltage: Before wiring, servicing or cleaning the heating system, turn off the power and follow your organization's lockout and tagout procedure. Failure to do so could allow others to turn on the power unexpectedly, resulting in harmful or fatal electrical shock.

NOTICE

Pump damage: Do not run the motor/pump assembly dry for more than five seconds at a time. Running a pump that is not completely filled with fluid will cause damage to the pump seal.

Proper heating operation: The high-limit temperature control relay (TCR2) must be set at least 18 °F (10 °C) higher than the control temperature control relay (TCR1) for proper heating operation. This will prevent nuisance tripping of the high-limit circuit.

3.3.1 FIRST RUN PROCEDURE

1. For three-phase applications, ensure a motor rotation check has been performed prior to introducing fluid to the pumps (see **SECTION 2.6.3**).

NOTE: Single-phase systems are prewired to ensure the pump motor rotates in the correct direction. A motor rotation check is not necessary for single-phase systems.

2. Check and tighten all electrical and plumbing connections.
3. Ensure isolation valves are **open** before energizing the system.
4. Bleed all trapped air from the heating system by opening a plug or pipe fitting at or near the pump. Press and hold the **PRIME** button to evacuate any remaining air in the lines.

NOTE: When priming the pump, the pressure gauge should indicate an increase in

pressure. Your system's operating pressure may vary depending on the configuration of the engine.

5. Turn the **LOCAL/OFF/REMOTE** switch to **LOCAL** or **REMOTE** to energize the heating system.
6. Once operation is satisfactory, turn the control dial on the temperature control relay TCR1 to the desired temperature setting for engine oil. HOTSTART recommends a control temperature on TCR1 of 104 °F (40 °C). The high-limit temperature setting on TCR2 should be set at 194 °F (90 °C). See **SECTION 3.1.2** and **SECTION 3.1.3**.
7. Turn the **LOCAL/OFF/REMOTE** switch to **REMOTE** to verify the 24 V DC remote signal connection (if installed).

4 MAINTENANCE AND TROUBLESHOOTING

4.1 SYSTEM FAULTS

A failure in the pump motor that causes the motor protection switch (MPS1 or MPS2) to trip will shut down the respective heating system. A fault signal will be transmitted. If this failure occurs, the **LOCAL/OFF/REMOTE** switch must be switched to **OFF** and the operator must press the **RESET** button (or the MPS reset button) to reset the fault. (See **SECTION 3.2.3**.)

If there is a failure that causes a high temperature to occur, the high-limit temperature controller (TCR2 or TCR4) will shut down the respective heating system, including the pump motor. A fault signal will be transmitted. To restart the system, the **LOCAL/OFF/REMOTE** switch must be switched to **OFF** and then back to **LOCAL** or **REMOTE** to resume operation once the fluid temperature drops below the high-limit preset (See **SECTION 3.1.3**). For additional troubleshooting, see **SECTION 4.5**.

4.1.1 COOLANT FAULTS

A fault signal will be transmitted if:

- The coolant pump motor protection switch is tripped (MPS1).
- The coolant high-limit temperature is exceeded (TCR2).

4.1.2 OIL FAULTS

A fault signal will be transmitted if:

- The oil pump motor protection switch is tripped (MPS2).
- The oil high-limit temperature is exceeded (TCR4).

4.2 SYSTEM MAINTENANCE



Hazardous voltage: Before wiring, servicing or cleaning the heating system, turn off the power and follow your organization's lockout and tagout procedure. Failure to do so could allow others to turn on the power unexpectedly, resulting in harmful or fatal electrical shock.

Instructions for the following maintenance procedures are provided to ensure trouble-free operation of your heating system. Replacement parts must meet or exceed original part requirements in order to maintain the compliance level of the original heating system.

NOTE: After maintenance is performed, refer to **SECTION 3.3.1** for system start-up procedures.

4.2.1 PLUMBING CONNECTIONS

Periodically check plumbing connections for leaks and, if necessary, tighten connections. A loose connection on the suction side will cause a loss of flow and cavitation in the pump. It can also pull air into the heating tank and cause an element failure.

4.2.2 ELECTRICAL CONNECTIONS

Vibration may cause terminals to loosen. At start-up, tighten electrical connections. Check connections again in a week. Tighten all electrical connections every three months.

4.2.3 SYSTEM MOUNTING

Vibration may cause mounting bolts to loosen. Periodically check and tighten all mounting bolts.

4.2.4 MAGNETIC CONTACTORS

Magnetic contactors are used as voltage switching controls for motors and heating elements in HOTSTART heating systems. The contactors use 120 volt or 240 volt coils. To test for failure, check for continuity across the coil connections; an open or direct-short reading indicates a failed contactor coil.

The contacts on the magnetic contactor should be inspected periodically for welding, arc erosion and mechanical wear. If any of these conditions exist, replace the magnetic contactor. HOTSTART recommends contactors be replaced every five years.

4.2.5 PUMP SEAL

If seal becomes worn, replacement pump seals are available. To ensure pump seal longevity, ensure

the supply lines do not restrict flow excessively (see **SECTION 2.1.1** and **SECTION 2.3.1**)

NOTE: Instructions to replace the pump seals are included with replacement seals.

4.2.6 PRESSURE RELIEF VALVE

The oil pump pressure relief valve is internal to the pump and releases pressure from the discharge side of the pump to the suction side of the pump. No maintenance for this part is required.

4.2.7 PRESSURE/ TEMPERATURE GAUGE

The oil pressure/temperature gauge will indicate a pressure increase when the pump motor is engaged by pressing the **PRIME** button or during normal heater operation. The gauge will also indicate the current fluid temperature. No maintenance for this part is required.

4.2.8 VOLATILE CORROSION INHIBITOR

A volatile corrosion inhibitor (VCI) is provided with each control box and should be replaced once a year.

NOTE: Heating systems placed in extended storage will require that the VCI is replaced at six month intervals. See **SECTION 4.4**.

4.2.9 TEMPERATURE CONTROL RELAY



Hazardous voltage: Before wiring, servicing or cleaning the heating system, turn off the power and follow your organization's lockout and tagout procedure. Failure to do so could allow others to turn on the power unexpectedly, resulting in harmful or fatal electrical shock.

If the OCLE heating system does not maintain the desired preset control temperature or signals a high-limit temperature fault immediately upon system start-up, the TCR (temperature control relay), the RTD (resistance temperature device), or the RTD cable may require replacement. To perform this troubleshooting, you will need:

- Ohmmeter
1. De-energize the heating system. Verify fluid is present and flow is not restricted. Check temperature gauge to ensure the liquid in the tank is below 122 °F (50 °C).
 2. Verify the control TCR is set correctly. Verify that high-limit TCR is set at least 18 °F (10 °C) higher than the control TCR set point.
 3. Using the ohmmeter, measure the resistance between TCR terminals **T1** and **T2** (See Fig. 8):
 - If the measured resistance is **between 80 and 120 ohms** continue troubleshooting. Proceed to step 4.
 - If the resistance is **lower than 80 ohms** or **higher than 120 ohms**, contact HOTSTART for further assistance.
 4. Using the ohmmeter, test for continuity between TCR terminals **T2** and **T3**:
 - If there **is continuity** between TCR terminals **T2** and **T3**, the TCR, RTD and RTD cable are functioning correctly. Close control panel. Allow fluid to cool below high-limit preset temperature. Perform system start-up (see **SECTION 4**). If fault or temperature problems persist after start-up, contact HOTSTART for further assistance.
 - If there **is no continuity** between TCR terminals **T2** and **T3**, locate connected RTD on the heating tank. Unscrew the RTD plug from RTD. See Table 2 and Fig. 10, Fig. 11 on following page.
 5. Using the ohmmeter, touch the probes to RTD lead **TS2:WHT (A)** and lead **TS2:RED (B)**. See Fig.

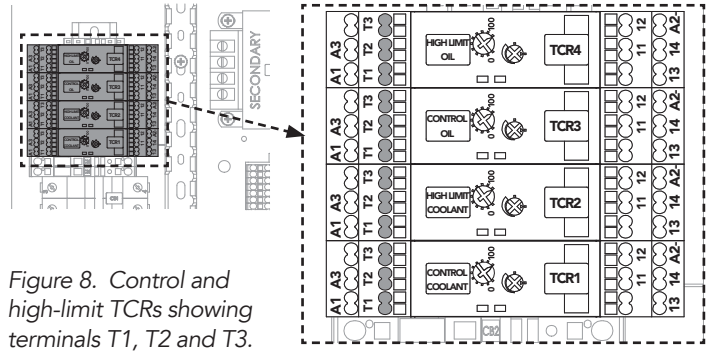

Figure 8. Control and high-limit TCRs showing terminals T1, T2 and T3.

TCR		TYPE		RTD Position
TCR1	Coolant	Control	50 °C	Coolant Tank Inlet
TCR2	Coolant	High-limit	90 °C	Coolant Tank Outlet
TCR3	Oil	Control	40 °C	Oil Tank Inlet
TCR4	Oil	High-limit	90 °C	Oil Tank Outlet

Table 2. TCR types, default temperature settings and corresponding RTD positions.

9. Note the resistance. Touch the probes to **lead TS2:RED (B)** and **lead TS2:RED (C)** to check for continuity:
 - If the resistance between RTD **lead TS2:WHT (A)** and **lead TS2:RED (B)** is **between 80 and 120 ohms** and there **is continuity** between RTD **TS2:RED (B)** and **lead TS2:RED (C)**, the RTD is functioning properly. Replace the RTD cable.
 - If the resistance between RTD **lead TS2:WHT (A)** and **lead TS2:RED (B)** is **not between 80 and 120 ohms** or there is **no continuity** between **lead TS2:RED (B)** and **lead TS2:RED (C)**, the RTD is malfunctioning. Replace the RTD.

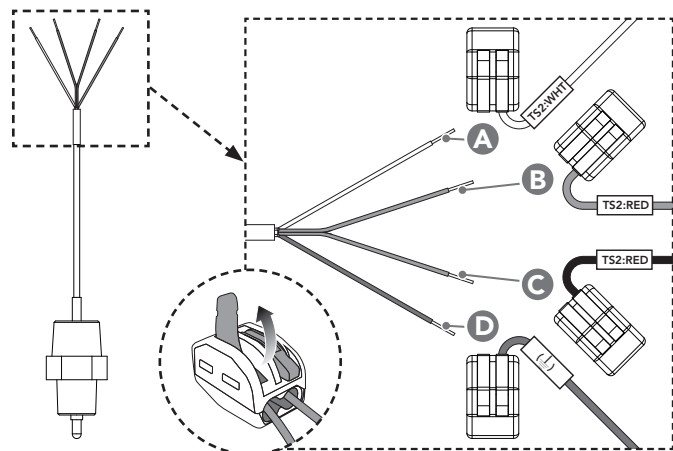

Figure 9. RTD leads and connectors shown on the RTD assembly, TSX:WHT (A), TSX:RED (red wire) (B), TSX:RED (black wire) (C), and Ground (D). Disconnect wire from connector as shown.

4.3 RECOMMENDED MAINTENANCE

INTERVAL	MAINTENANCE TASK
At initial start-up	Tighten electrical connections. See SECTION 3.3.1
One week after initial start-up	Check and tighten electrical connections. See SECTION 4.2.2.
Every three months	Tighten electrical connections.
Annually	Drain, clean and flush heating system.
	Check for cracked or weakened hoses and replace if necessary.
	Check electrical wiring and connections for wear and excessive heat.
	Check mounting bolts and tighten if necessary.
	Remove element and clean element and tank.
Every five years	Replace magnetic contactors. See SECTION 4.2.4.

4.4 STORAGE REQUIREMENTS

If long-term storage is necessary, precautions must be taken to ensure that the heating system is operational for start-up. Steps must be taken to ensure that water ingress is mitigated at all locations. All plugs and caps must remain tight and a suitable cover must be provided for the system. The cover must shield the system from direct rain and protect from any directed spray that may occur.

For any storage longer than three months, desiccant bags must be placed next to the system if it is still in the original packaging and inside the control box. If the storage duration will be one year or longer, the volatile corrosion inhibitor inside the control box must be replaced at six month intervals.

New pump motors placed in long-term storage for a year or longer may require relubrication before initial use. If your pump motor has provisions for relubrication, refer to the pump motor manufacturer's relubrication recommendations. Refer to the pump motor nameplate for lubrication type.

4.5 TROUBLESHOOTING

SYMPTOM	POSSIBLE CAUSES	SOLUTION
System fault	Pump not primed properly	Bleed all trapped air from lines. Restart system.
	Isolation valves may be closed	Open valves. Restart system.
	Hose kinked or crushed	Remove obstruction. Restart system.
	Leak in suction line	Repair leak. Restart system.
	Pump motor turning backwards	Reverse any two leads on power (in three-phase system). Restart system. See SECTION 3.3.1 .
	Control TCR failure: closed	Check and replace if necessary. See SECTION 4.2.9 .
	Motor failure	Check and replace if necessary. Restart system.
	Motor contactor failure	Check contacts and replace if needed. Restart system.
	Motor protection switch tripped	Check and reset switch. If problem occurs again, check motor. Restart system.
	RTD failure	Check TCR and RTD. See SECTION 4.2.9 .
	RTD cable failure	Check TCR and RTD. See SECTION 4.2.9 .
Fluid temperature too low	Motor failure	Check motor. Replace if necessary.
	Heater has been turned off and fluid is cold	Allow time for the heating system to heat fluid.
	Heating element failed	Check elements for continuity. Replace element if necessary.
	Element breaker tripped	Check for element short to ground. If no short, reset breaker.
	Element contactor failed	Check contacts and coil. Replace if necessary.
	Motor contactor failed	Check contacts and coil. Replace if necessary.
	Control TCR failure: open	Check and replace if necessary. See SECTION 4.2.9 .
	Control TCR set point too low	Adjust set point for control TCR. See SECTION 3.1.2 .
	RTD failure	Check TCR and RTD. See SECTION 4.2.9 .
	RTD cable failure	Check TCR and RTD. See SECTION 4.2.9 .