



Customer Support: (509) 536-8660  
 sales@hotstart.com  
 www.hotstart.com

## Installation Instructions CTM Circulating System

**READ CAREFULLY FOR PROPER INSTALLATION & OPERATION**

### CAUTION

**Heater Damage:** Do not connect unit to electricity until the following steps have been completed. Never operate heater in air (verify heater is full of coolant and properly plumbed).

### INSTALLATION RECOMMENDATIONS

1. Drain and thoroughly flush cooling system.
2. Mount heater as shown in a vertical position. Attach the heater as low as possible to the equipment frame or other suitable area. Heater should be below the lowest level of the engine water jacket and the heater intake must be below the point where coolant is removed from the engine.

### NOTICE

**Vibration Damage:** Do not mount the heater directly to the engine or any locations directly connected to the engine.

3. Install 5/8" (16 mm) heater hose between the heater inlet (suction) and the engine. Locate the suction port of the engine as close to directly above the heater as possible and well below the highest coolant level in the engine. This will enhance air evacuation from the heater at start up and will insure the heater has a supply of coolant at all times.
4. Install 5/8" (16 mm) heater hose between the heater outlet (discharge) and the engine block. Locate the discharge port as far as possible from the suction port to enhance heat distribution throughout the engine.
5. Refill cooling system. Start engine and run for about 10 minutes to eliminate airlocks and ensure proper circulation. Shut off engine. Check for leaks. Re-tighten hose clamps where necessary. Let engine cool. Check coolant level, add if necessary.
6. Fasten cord at intervals with tape or wire ties to avoid contact with all hot or moving parts.
7. Connect the heater to properly grounded electrical power. Check heater for proper operation. Check at regular intervals (up to an hour) by feeling the hoses. The outlet hose should be warm and the inlet hose relatively cool. If the bottom hose becomes warm before the entire system, the coolant may not be circulating.

### THERMOSTAT ADJUSTMENT

1. Disconnect the heater from electrical power.
2. Remove the four screws holding the electrical cover in place.
3. While holding the two strain reliefs in place, remove the top electrical cover.
4. Adjust the thermostat to the appropriate setting. It is factory set at 110F (43C). When the water temperature is greater than this set point, the heater turns off, and it will reenergize when the temperature falls 20F (11C) below the set point.
5. Replace the cover, torque the screws to 25 in-lbs (2.8 N-m) in a diagonal pattern and reconnect to electrical power.
6. Verify heater and pump are cycling appropriately with the thermostat.

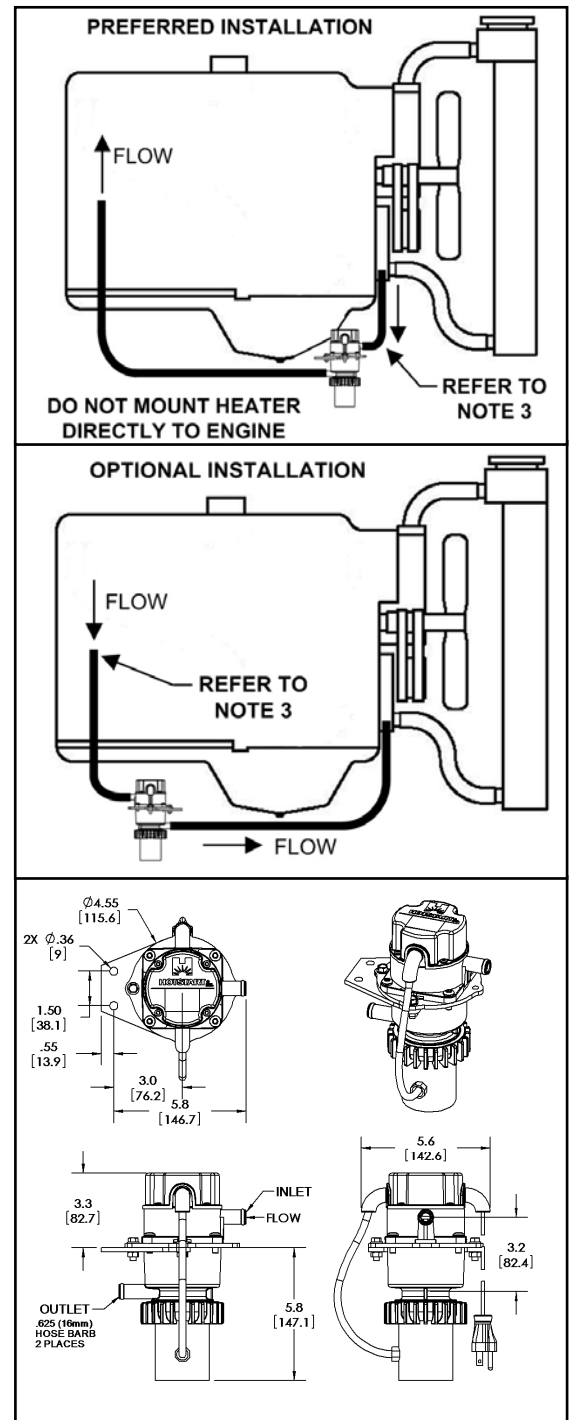

## ADJUSTMENT OF INLET AND OUTLET PORT ORIENTATIONS

1. Disconnect the heater from electrical power and ensure water is drained or shut off to the heater.
2. Remove the four screws holding the tank body.
3. Loosen the pump nut
4. Orient pump inlet to desired location (90° increments) and hand-tighten pump nut.
5. Reseat o-ring in groove

### NOTICE

O-ring Damage: Ensure the o-ring is properly seated in the groove to prevent leakage from the heater.

6. Assemble tank body and torque screws to 75 in-lbs (8.5 N-m), using a diagonal pattern.

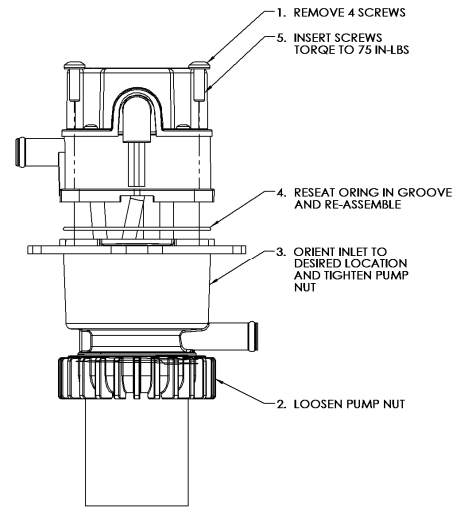

## THERMOSTAT REPLACEMENT

1. Disconnect the heater from electrical power.
2. Remove the four screws holding the electrical cover in place.
3. Remove the quick disconnects from existing thermostat.
4. Remove screw from the thermostat bracket.
5. Replace Thermostat and reassemble in reverse order.
6. Torque electrical cover screws to 25 in-lbs (2.8 N-m).

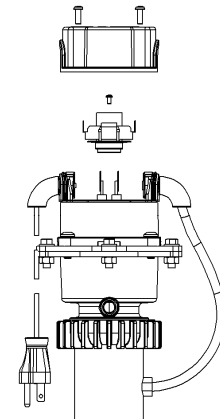

THERMOSTAT REPLACEMENT

